

**Bau-
form 4**
Förderrichtung V

**Con-
struction 4**
Air flow direction V

**Forma
costruttiva 4**
Direzione V

**Forme de
construction 4**
Sens d'écoulement de l'air V

**Forma
construttiva 4**
Dirección V

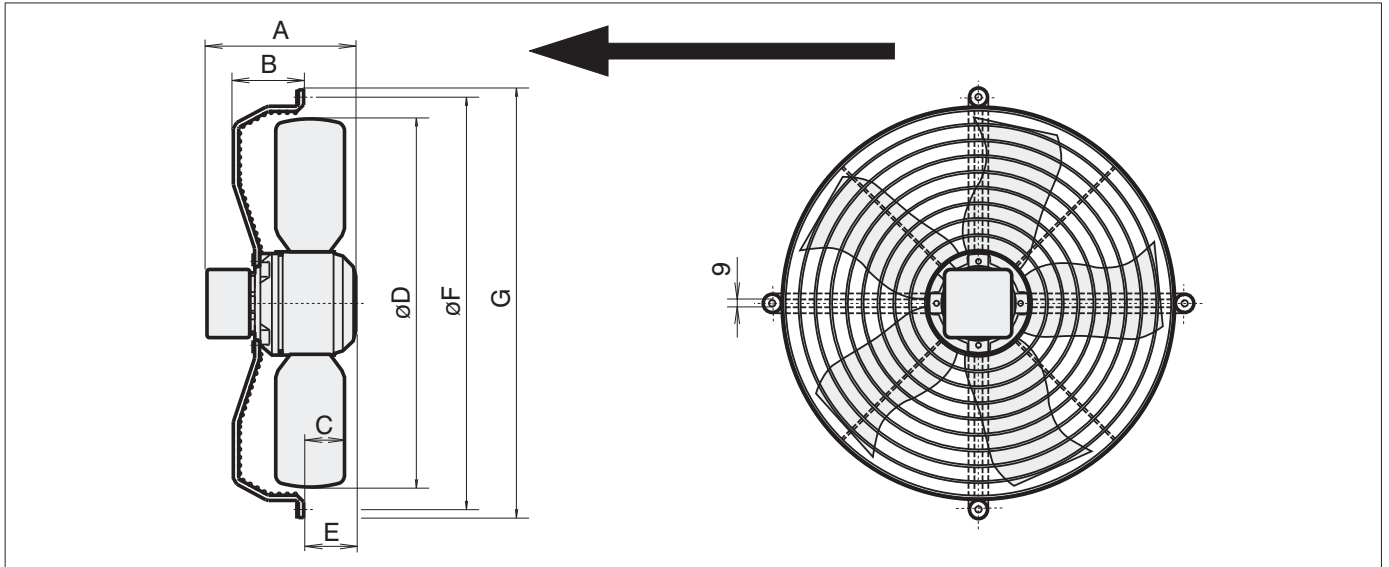

AKS ...	Motor	Typ	A [mm]	B [mm]	C [mm]	D [mm]	E [mm]	F [mm]	G [mm]	[kg]
350	80-42	-	184	85	40	350	62	422	442	5,5
400	80-55	-	197	85	42	398	75	470	500	6,0
450	80-55	-	197	96	35	446	65	515	546	6,8
450*	106-50	N	203	96	50	446	72	515	546	10,0
450*	106-70	N	203	96	50	446	92	515	546	11,5
500*	106-35	K	188	96	45	498	57	565	596	9,0
500*	106-50	N	203	96	55	498	72	565	596	10,2
500*	106-70	K	223	96	45	498	92	565	596	12,0
500*	106-70	N	223	96	55	498	92	565	596	12,0
560	106-35	K	188	100	26	552	53	700	725	9,5
560	106-50	K	203	100	26	552	68	700	725	10,5
560	106-70	K	223	100	26	552	88	700	725	12,5
630	106-50	K	203	98	28	628	70	750	791	11,5
630	106-70	N	223	98	38	628	90	750	791	13,5
630	106-70	N	223	98	38	628	90	750	791	13,5
630	106-90	N	243	98	38	628	110	750	791	15,5

* = Ausführung nur mit Klemmenkasten möglich