

1. General	1
2. Specifications and description of design	1
2.1 Compressor nomenclature	1
2.2 Compressor specifications	2
2.3 RC2 series compressor construction	4
2.4 Design features	6
2.5 Compression process	7
2.6 Capacity control system	7
2.7 3 or 4-step capacity control system	8
2.8 Continuous (stepless) capacity control system	9
2.9 Dual capacity control system (optional)	11
3. Lubricants	17
4. Compressor handling and installation	19
4.1 Compressor lifting	19
4.2 Mounting the compressor	20
4.3 RC2 compressor outline drawings	21
4.4 Compressors accessories	41
4.5 Installation and connection of compressor	55
5. Electrical data and design	58
5.1 Motor design	58
5.2 Compressor protection devices	61
5.3 Power supply	61
5.4 Grounding	62
5.5 Torque Value for power bolts	62
6. Operation and maintenance	63
6.1 Compressor start-up	63
6.2 Troubleshooting	64
6.3 Compressor checking list	65
7. Applications	66
7.1 Additional cooling	66
7.2 Economizer applications	69
7.3 Parallel system applications	70
7.4 Oil pump application	71
7.5 Important note of applications of compressor	71
8 Selection software	72
9. Warranty	74
Appendix. RC2 Compressor noise level	75

1. General

HANBELL **RC2** series semi-hermetic screw compressor is developed especially for applications in air-conditioning and refrigeration. With high operating load design, each HANBELL compressor is of high efficiency and reliability in all operating conditions such as thermal storage, heat pump system & refrigeration. Each HANBELL compressor has the latest and advanced **5-to-6 Patented Screw Rotor Profile** designed to ensure high capacity and efficiency in all operating conditions. Each unit is carefully manufactured and inspected by high precision **THREAD SCREW ROTOR GRINDING MACHINE, CNC MACHINING CENTER, and 3D COORDINATE MEASURING MACHINE**. Each **HANBELL** compressor follows **ISO 9001** quality system. This certification assures that its quality is controlled under severe quality procedures and good service to all customers.

RC2 series compressor is equipped with separated radial and axial bearings, liquid injection and economizer connection, PTC motor temperature thermistors and discharge temperature thermistors, a motor protector, and oil level switch and oil pressure differential switch connector and other accessories. The complete accessories and their new designs guarantee the compressor has the best reliability, longest bearing life during heavy duty running and strict operating conditions.

This Technical Manual contains information about lifting, dimensions, installation, operation, applications and basic trouble-shooting. It is strongly recommended that contents of this manual should be referred carefully prior to lifting, installation, and commissioning of RC2 series compressor in order to prevent any accident or damage. Please contact HANBELL or its local distributors/agents for more information or further assistance.

2. Specifications and description of design

2.1 Compressor nomenclature

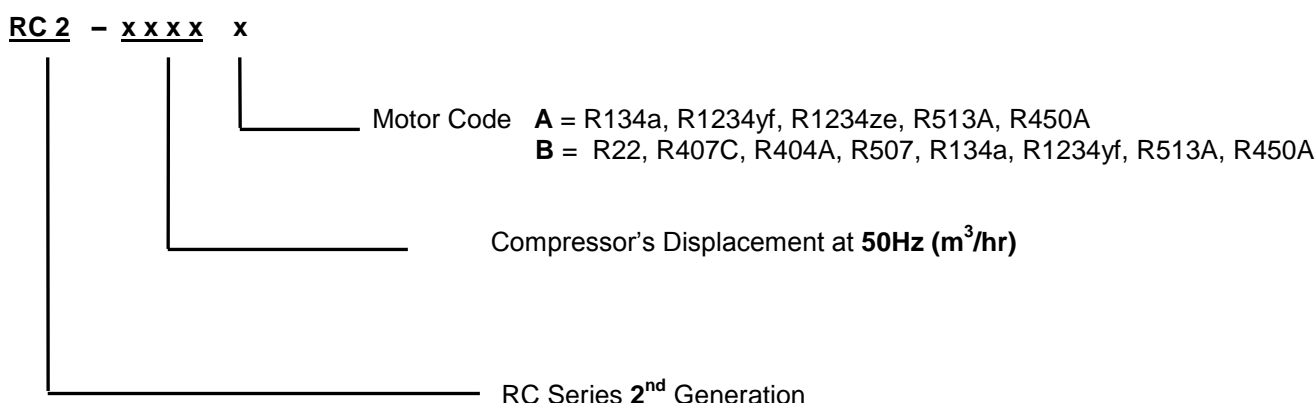



2.2 Compressor specifications

a. RC2-A

MODEL	COMPRESSOR				MOTOR						Lubricant charge	Oil Heater	Hydrostatic Pressure Test	WEIGHT			
	Displacement 60 / 50Hz m ³ /hr	Rated Speed 60 / 50Hz	VI	Cap. Control (%)		Type	Nominal Hp		Starting	Voltage (V)					Insulation	Protection	
				STEP	STEPLESS		60Hz	50Hz		60Hz							50Hz
RC2-100A	118/98	3550/2950	2.2 2.6 3.0 3.5 4.8	33, 66, 100	33~100	3 Phase, 2 Pole, Squirrel Cage, Induction Motor	23	19	Y-Δ PWS DOL	208 220 230 380 440 460 480 575	Class F	PTC Protection	L	W	Kg/cm2G	kg	
RC2-140A	165/137			33, 66, 100	33~100		32	26					7	275			
RC2-180A	216/180			33, 66, 100	33~100		42	35					7	280			
RC2-200A	233/193			25, 50, 75, 100	25~100		45	37					8	300			
RC2-230A	277/230			35, 50, 75, 100	35~100		53	44					14	420			
RC2-260A	309/257			25, 50, 75, 100	25~100		59	49					14	540			
RC2-300A	352/293			25, 50, 75, 100	25~100		67	56					16	590			
RC2-310A	371/308			35, 50, 75, 100	35~100		71	59					16	575			
RC2-340A	407/339			35, 50, 75, 100	35~100		77	64					16	600			
RC2-370A	440/366			35, 50, 75, 100	35~100		84	70					16	610			
RC2-410A	490/407			25, 50, 75, 100	25~100		93	78	16	730							
RC2-470A	567/471			25, 50, 75, 100	25~100		108	90	18	800							
RC2-510A	611/508			35, 50, 75, 100	35~100		117	98	20	760							
RC2-550A	660/549			25, 50, 75, 100	25~100		126	105	23	820							
RC2-580A	702/583			35, 50, 75, 100	35~100		131	109	20	805							
RC2-620A	745/619			35, 50, 75, 100	35~100		137	114	23	850							
RC2-710A	858/713			35, 50, 75, 100	35~100		158	131	28	1100							
RC2-790A	952/791			30, 50, 75, 100	30~100		175	146	28	1140							
RC2-830A	993/825			30, 50, 75, 100	30~100		183	152	28	1150							
RC2-930A	1117/929			35, 50, 75, 100	35~100		212	176	28	1180							
RC2-1020A	1223/1017	25, 50, 75, 100	25~100	227	189	40	1500										
RC2-1130A	1350/1122	25, 50, 75, 100	25~100	248	206	40	1520										
RC2-1270A	1521/1268	25, 50, 75, 100	25~100	286	238	53	2100										
RC2-1530A	1847/1539	25, 50, 75, 100	25~100	331	275	53	2200										

Nominal Horse Power:

All the above Nominal Hp's are not equal to the maximum compressor Hp. Please refer to Hanbell selection software's output for rated current and Maximum Continuous Current-M.C.C according to various operating conditions while selecting sizes of contactor, cable, fuse and wire, etc...



b. RC2-B

MODEL	COMPRESSOR				MOTOR								Lubricant charge	Oil		Hydrostatic Pressure Test	WEIGHT
	Displacement 60 / 50Hz	Rated Speed	VI	Cap. Control (%)		Type	Nominal Hp		Starting	Voltage (V)		Insulation		Protection	Heater		
				m ³ /hr	60 / 50Hz		STEP	STEPLESS		60Hz	50Hz		60Hz			50Hz	L
RC2-100B	118/98	3550/2950	2.2 2.6 3.0 3.5 4.8	33, 66, 100	33-100	3 Phase, 2 Pole, Squirrel Cage, Induction Motor	38	31	Y-Δ	208 220 230 380 440 460 480 575	Class F	PTC Protection	150/300	42		7	280
RC2-140B	165/137			33, 66, 100	33-100		50	41								7	285
RC2-180B	216/180			33, 66, 100	33-100		66	55								7	335
RC2-200B	233/193			25, 50, 75, 100	25-100		70	58								8	425
RC2-230B	277/230			35, 50, 75, 100	35-100		81	67								14	555
RC2-260B	309/257			25, 50, 75, 100	25-100		90	75								14	560
RC2-300B	352/293			25, 50, 75, 100	25-100		107	89								16	600
RC2-310B	371/308			35, 50, 75, 100	35-100		110	91								16	580
RC2-340B	407/339			35, 50, 75, 100	35-100		121	101								16	620
RC2-370B	440/366			35, 50, 75, 100	35-100		130	108								16	640
RC2-410B	490/407			25, 50, 75, 100	25-100		146	121	16	740							
RC2-470B	567/471			25, 50, 75, 100	25-100		170	141	18	810							
RC2-510B	611/508			35, 50, 75, 100	35-100		183	152	20	780							
RC2-550B	660/549			25, 50, 75, 100	25-100		195	162	23	850							
RC2-580B	702/583			35, 50, 75, 100	35-100		210	175	20	840							
RC2-620B	745/619			35, 50, 75, 100	35-100		220	183	23	880							
RC2-710B	858/713			35, 50, 75, 100	35-100		250	208	28	1100							
RC2-790B	952/791			30, 50, 75, 100	30-100		276	230	28	1180							
RC2-830B	993/825			30, 50, 75, 100	30-100		290	234	28	1215							
RC2-930B	1117/929			35, 50, 75, 100	35-100		334	278	28	1240							
RC2-1020B	1223/1017	25, 50, 75, 100	25-100	357	297	40	1540										
RC2-1130B	1350/1122	25, 50, 75, 100	25-100	393	327	40	1560										
RC2-1270B	1521/1268	25, 50, 75, 100	25-100	471	392	53	2200										
RC2-1530B	1847/1539	25, 50, 75, 100	25-100	534	443	53	2300										

Nominal Horse Power:

All above Nominal Hp are not equal to the maximum compressors Hp; Please refer to Hanbell selection software's output for the rated current, Maximum Continuous Current-M.C.C according to various working condition while selecting the contactor, cable, fuse and wire, etc...



2.3 RC2 series compressor construction

RC2-100, RC2-140, RC2-180 Construction

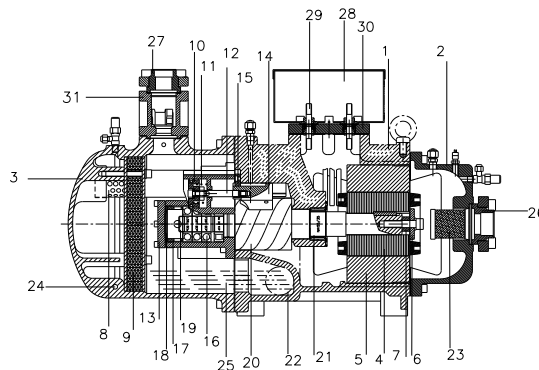

Figure 1

Item	Description	Item	Description	Item	Description	Item	Description
1	Compressor casing	9	Oil separator cartridge	17	Discharge fixed ring	25	Refrigeration Lubricant
2	Motor casing	10	Piston	18	Disc spring	26	Suction flange
3	Oil separator	11	Piston spring	19	Bearing lock nut	27	Discharge flange
4	Motor rotor assembly	12	Piston rod	20	Male rotor	28	Cable box
5	Motor stator assembly	13	Bearing seat's cover plate	21	Suction bearings	29	Power bolt
6	Motor rotor washer	14	Modulation slide valve	22	Oil filter cartridge	30	Motor cable cover plate
7	Motor rotor spacer ring	15	Slide valve key	23	Suction filter	31	Discharge check valve
8	Oil separator baffle	16	Discharge bearings	24	Oil heater		

RC2-200, RC2-230, RC2-260, RC2-300, RC2-310, RC2-340, RC2-370, RC2-410, RC2-470, RC2-510, RC2-580 Construction

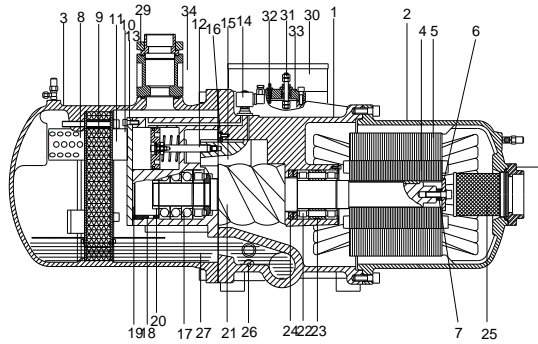

Figure 2

Item	Description	Item	Description	Item	Description	Item	Description
1	Compressor casing	10	Piston	19	Disc spring	28	Suction flange
2	Motor casing	11	Piston spring	20	Bearing lock nut	29	Discharge flange
3	Oil separator	12	Piston rod	21	Male rotor	30	Cable box
4	Motor rotor assembly	13	Bearing seat's cover plate	22	Suction bearings	31	Power bolt
5	Motor stator assembly	14	Modulation solenoid valve	23	Suction bearings inner/outer spacer ring	32	Thermostat terminals
6	Motor rotor washer	15	Modulation slide valve	24	Oil guiding ring	33	Motor cable cover plate
7	Motor rotor spacer ring	16	Slide valve key	25	Suction filter	34	Discharge check valve
8	Oil separator baffle	17	Discharge bearings	26	Oil heater		
9	Oil separator cartridge	18	Discharge fixed ring	27	Refrigeration Lubricant		

RC2-550, RC2-620 Construction

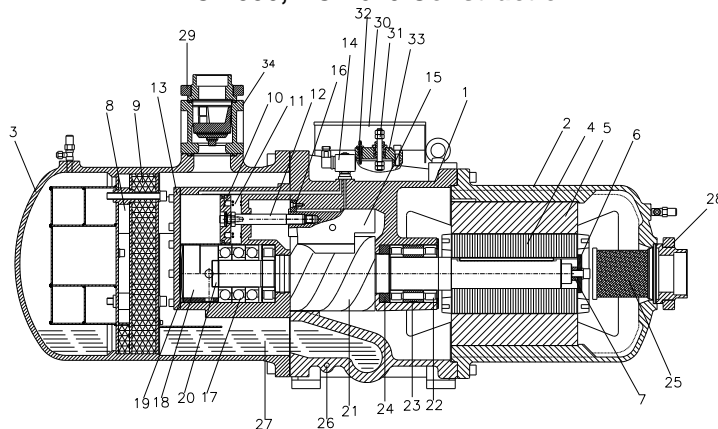

Figure 3

Item	Description	Item	Description	Item	Description	Item	Description
1	Compressor casing	10	Piston	19	Disc spring	28	Suction flange
2	Motor casing	11	Piston spring	20	Bearing lock nut	29	Discharge flange
3	Oil separator	12	Piston rod	21	Male rotor	30	Cable box
4	Motor rotor assembly	13	Bearing seat's cover plate	22	Suction bearings	31	Power bolt
5	Motor stator assembly	14	Modulation solenoid valve	23	Suction bearings inner/outer spacer ring	32	Thermostat terminals
6	Motor rotor washer	15	Modulation slide valve	24	Oil guiding ring	33	Motor cable cover plate
7	Motor rotor spacer ring	16	Slide valve key	25	Suction filter	34	Discharge check valve
8	Oil separator baffle	17	Discharge bearings	26	Oil heater		
9	Oil separator cartridge	18	Discharge fixed ring	27	Refrigeration Lubricant		

RC2-710, RC2-790, RC2-830, RC2-930 Construction

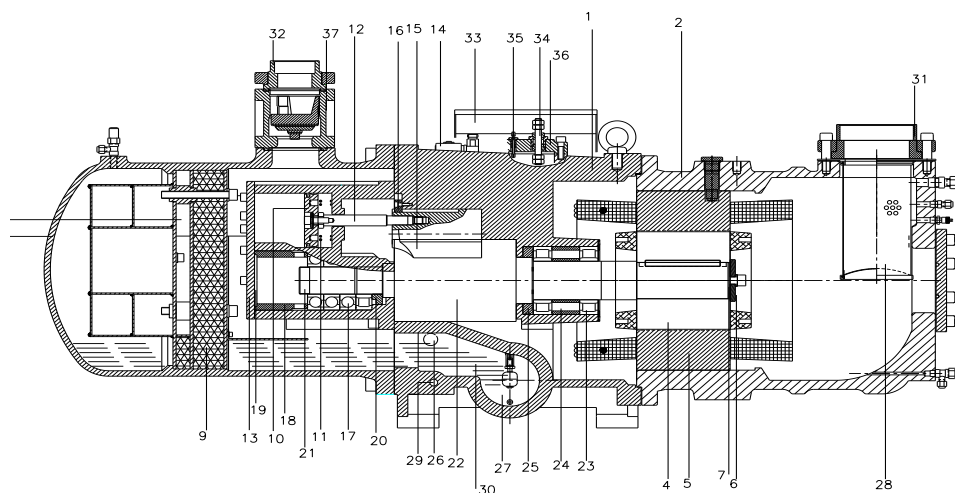

Figure 4

Item	Description	Item	Description	Item	Description
1	Compressor casing	11	Piston spring	21	Bearing lock nut
2	Motor casing	12	Piston rod	22	Male rotor
3	Oil separator	13	Bearing seat cover plate	23	Suction bearings
4	Motor rotor assembly	14	Modulation solenoid valve	24	Suction bearings inner/outer spacer ring
5	Motor stator assembly	15	Modulation slide valve	25	Oil guiding ring
6	Motor rotor washer	16	Slide valve key	26	Oil level sight glass
7	Motor rotor spacer ring	17	Discharge bearings	27	Oil filler cartridge
8	Oil separator baffle	18	Discharge fixed ring	28	Suction filter
9	Oil separator cartridge	19	Disc spring	29	Oil heater
10	Piston	20	α-Balance piston	30	Refrigeration Lubricant
				31	Suction flange
				32	Discharge flange
				33	Cable box
				34	Power bolt
				35	Thermostat terminals
				36	Motor cable cover plate
				37	Discharge check valve

RC2-1020, RC2-1130, RC2-1270, RC2-1530 Construction

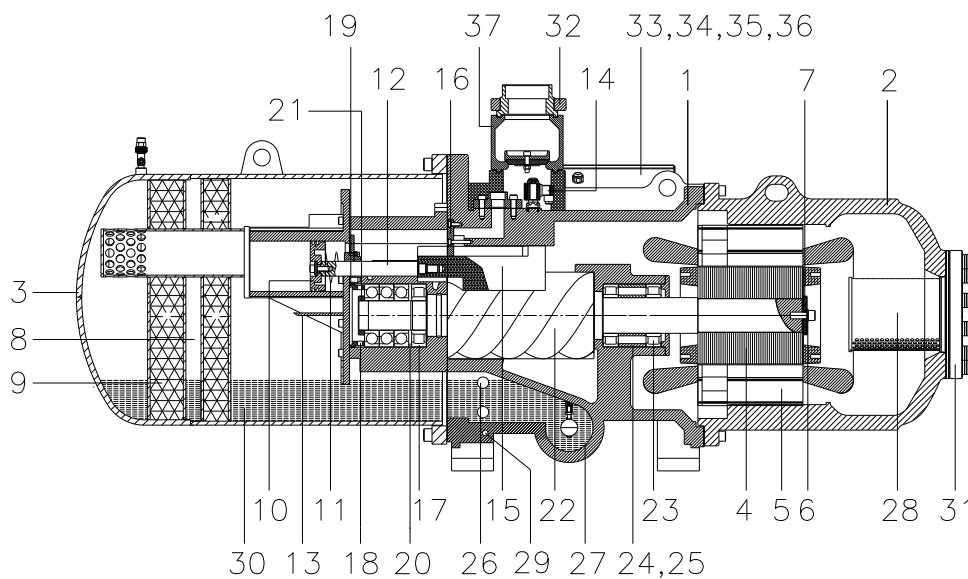

Figure 5

Item	Description	Item	Description
1	Compressor casing	20	Balance piston
2	Motor casing	21	Bearing slot nut
3	Oil separator	22	Male rotor
4	Motor rotor assembly	23	Suction bearings
5	Motor stator assembly	24	Suction bearings inner/outer spacer ring
6	Motor rotor washer	25	Oil guiding ring
7	Motor rotor spacer ring	26	Oil level sight glass
8	Oil separator Baffle	27	Oil filler cartridge
9	Oil separator cartridge	28	Suction filter
10	Piston	29	Oil heater
11	Piston spring	30	Refrigeration Lubricant
12	Piston rod	31	Suction flange
13	Bearing seat cover plate	32	Discharge flange
14	Modulation solenoid valve	33	Cable box
15	Modulation slide valve	34	Power bolt
16	Slide valve key	35	Thermostat terminals
17	Discharge bearings	36	Motor cable cover plate
18	Discharge fixed ring	37	Discharge check valve
19	Disc spring		



2.4 Design features

HANBELL screw compressors feature simple and robust construction by elimination of some components such as pistons, piston rings, valve plates, oil pumps which are found in reciprocating compressors. Without these components, screw compressors run with low noise level, minimized vibration, high reliability and durability. HANBELL screw compressors are of two-shaft rotary displacement design with the latest and advanced 5:6 patented screw rotors. Screw rotors are precisely installed with roller bearings, i.e. radial bearings at both suction and discharge ends as well as angular contact ball bearings i.e. axial bearings at discharge end. A three-phase, two-pole squirrel-cage induction motor drives the compressor. The motor rotor is located on the shaft of the male screw rotor. Cooling of the motor is achieved with suction refrigerant vapor.

Compressor technical features:

Full product range- RC2 series compressor consists of 26 models with displacement ranging from 98/118 m³/hr up to 1539/1847 m³/hr (50/60Hz) compatible for different refrigerants and applications.

Multinational patents of high-efficiency screw rotors- The new 5:6 high efficiency screw rotor profile is patented in Taiwan, UK, US, and China. This new large-volume, high-efficiency rotor profile is designed especially for modern refrigerant characteristics. High-efficiency screw rotors are accomplished by using precision CNC machining centers, rotor milling machines, rotor grinding machines. Strict ISO 9001 process controlling and the application of precise inspection equipments, such as ZEISS 3D coordinate measuring machines, ensure high-efficiency, high-quality, low-noise and low-vibration HANBELL RC2 series screw compressors.

High efficiency motor- Premium grade low-loss core steel with special motor cooling slot and refrigerant guide vane which pilot the cold suction refrigerant gas through the motor provides the highest operating efficiency possible no matter how strict operating conditions are.

Long life bearings and high reliability- The screw compressors utilize a combination of 10 axial and radial bearings and a axial balance piston to ensure longer bearing life and higher compressor reliability.

Double-walled rotor housing- Double casing structure with high strength inner ribs has been designed to minimize noise and ensure rigidity. The rotor housing is made of high-strength gray cast iron FC25 that is extremely stable, therefore no expansion will occur even at high-pressure condition. These casings are machined by computer aided machining centers and inspected by precision measuring machines to enhance reliability.

Direct flange-on oil separator- A vessel made of ductile material FC 500 specially designed to withstand high pressure and provide the highest efficiency of oil separation. Simple oil management, three-staged oil separator(models above RC2-1020), low-pressure-drop demister to ensure the minimum refrigerant dilution in the oil and maintain high oil viscosity.

Precise capacity control- The slide valve for capacity control is located in the compressor chamber. The slide valve is actuated by injection of pressurized oil into the cylinder from the oil sump as well as bypass of oil through solenoid valves in each oil lines with pressure differential.

Perceptive protection modules- RC2 series screw compressors are equipped with PTC thermistors and motor protection module which could monitor discharge and motor coil temperatures as well as phase sequence and phase loss. Accessories also include oil level switch to monitor the level of oil, pressure differential switch, and pressure relief valve for optional application.

Adaptable with additional cooling- Liquid injection connection port located at the motor casing and in the compression chamber, oil cooler connection port, and middle pressure economizer connection port for customer's desired application.

RC2 series compressors not only continue RC series compressors' characteristics of high efficiency & reliability design mentioned above, but are also designed with the following newly added advantages to meet customers' needs more adequately:

1. Design the fittest high-efficiency motor for respective refrigerant, operation condition and electrical power.
2. Dual capacity control of steps or continuous create more accurate and reliable mechanism (Option)
3. Part load effective economizer application.

Detailed description of new design features are given in the following chapters.

2.5 Compression process

(A) Suction and sealing:

At the beginning of the compression cycle, as the male rotor and female rotor unmesh, gas from suction port fills the interlobe space (refer to the dark area below). Refrigerant at suction pressure continues to fill it, until the trailing lobe crosses the suction area and the gas is trapped inside the interlobe space.

(B) Compression:

As the male rotor and female rotor meshes, the interlobe space moves towards to discharge end and its volume decreases so that gas pressure increases consequently.

(C) Discharge:

Gas is discharged from the interlobe space when the leading lobe crosses the discharge port whose volume ratio is designed differently for various applications.

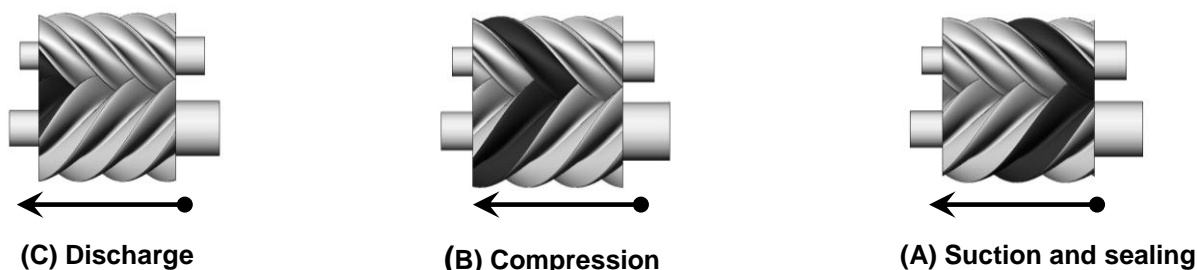

Figure 6 Compression process

2.6 Capacity control system

The RC2 series screw compressors are equipped with either 3-step/4-step capacity control system or continuous (step-less) capacity control system. Both of the capacity control systems consist of a modulation slide valve, piston rod, cylinder, piston and piston rings. The slide valve and the piston are connected by a piston rod. The principle of operation is using the oil pressure to drive the piston in the cylinder. See Figure 7, the lubrication oil flows from the oil sump through the oil filter cartridge and capillary then fills into the cylinder due to the positive oil pressure bigger than the right side of spring force plus the high pressure gas. The positive pressure differential causes the piston to move toward the right side in the cylinder. When the slide valve moves toward the right side, the effective compression volume in the compression chamber increases. This means the displacement of refrigerant gas also increases, as a result the refrigeration capacity also increases. However, when any of the step solenoid valve (for 3-step/4-step capacity control system) is opened, the high pressure oil in the cylinder bypasses to the suction side, which causes the piston and the slide valve to move toward the left side, and then some of the refrigerant gas bypasses from the compression chamber back to the suction end. As a result, the refrigeration capacity decreases because of the reduction of displacement of refrigerant gas flowing in the system.

The piston spring is used to push the piston back to its original position, i.e. minimum load position in order to reduce the starting current for the next starting. If the compressor started at full load capacity it may result in over current start. The capillary is used to maintain and restrain a suitable amount of oil flow into the cylinder. The modulation (stepless) solenoid valves (SV1 and SV2) are controlled by a micro controller or temperature switch to modulate the piston position smoothly with stable output of capacity.

If the oil filter cartridge, capillary, or modulation solenoid valves are not working well in the capacity control system, this may result in the abnormality and ineffectiveness of the capacity control system. **Before stopping the compressor, HANBELL strongly recommends that the unloading solenoid valve of stepless control system or minimum load solenoid valve of 3/4-step control system should be kept opened for 60~90 seconds so that oil pressure in the cylinder could be released. When starting the compressor again, it is in unloading position for light duty start.**

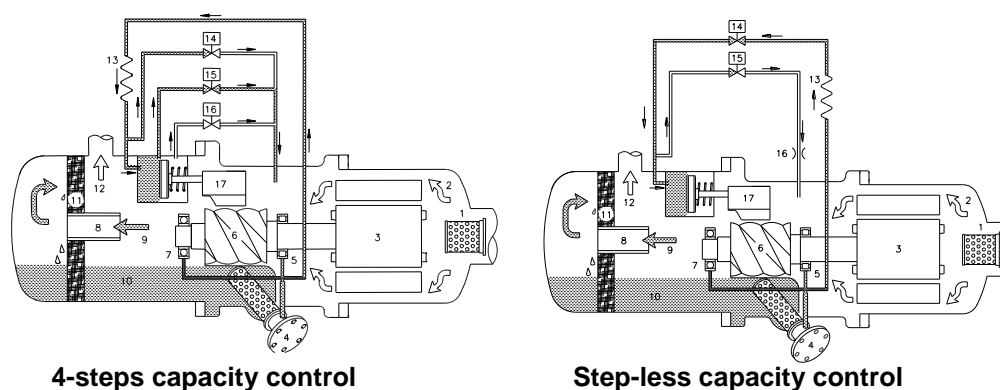
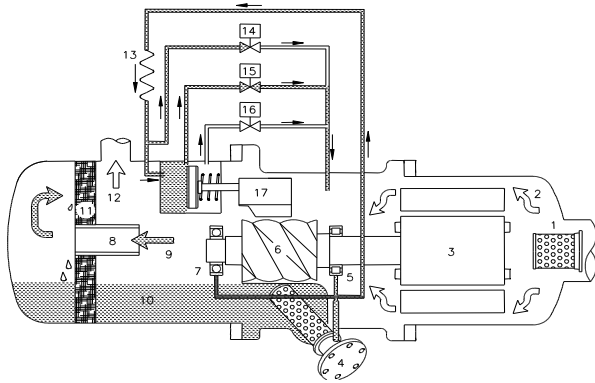

Figure 7 Capacity control system



2.7 3 or 4-step capacity control system

There are two (For RC2-100, RC2-140, RC2-180) or three (for the rest 23 models) solenoid valves installed on the compressor that control the compressor capacity from minimum capacity (please refer to chapter 2.2 for different minimum capacity of each model) to full load (100%). There are two / three normally closed (NC) solenoid valves used to control the various required capacity. For the compressor with 3-step / 4-step capacity control system, it is usual to use the sequence of min%-66%-100% / min%-50%-75%-100% to load the capacity of compressor and to use the sequence of 100%-66%-min.%/100%-75%-50%-min% to unload the capacity. If min% capacity is kept for a long time, the problem of oil return, motor cooling, high discharge temperature need to be solved by adding accessories such as oil level switch for monitoring the oil level, liquid injection devices for cooling motor coil and reducing discharge temperature.(Figure 8). Min% is recommended for start and stop only, not for long-termed operation.



No.	Component	No.	Component	No.	Component
1	Suction filter	7	Discharge bearings	13	Capillary
2	Gas in (low pressure)	8	Oil separator baffle	14	Solenoid valve (min. %), SV 25%/33%
3	Motor	9	Gas out (high pressure with oil)	15	Solenoid valve (50% of full load),SV50%
4	Oil filter cartridge	10	Lubricant	16	Solenoid valve (75%/66% of full load),SV75%/66%
5	Suction bearings	11	Oil separator demister	17	Slide valve
6	Male rotor	12	Gas out (high pressure without oil)	*	For RC2-100, 140 & 180 the SV 50%omitted

Figure 8 4-step capacity control

RC2-100,140,180 capacity control system	SV33%(NC)	SV66%(NC)
100% of full load	not energized	not energized
66% of full load	not energized	energized
33% (for start)	energized	not energized

RC2-200~1530 capacity control system	SV25%(NC)	SV75%(NC)	SV50%(NC)
100% full load	not energized	not energized	not energized
75% of full load	not energized	energized	not energized
50% of full load	not energized	not energized	energized
25% (for start)	Energized	not energized	not energized

Note: For 3-step or 4-step capacity control system, Hanbell equips normally-closed (NC) solenoid valves as standard accessory. If normally-opened (NO) solenoid valves are preferred instead, please specify it to Hanbell when placing order.

a. min% capacity

When starting the compressor, SV25%/33% solenoid valve is energized and the piston is in min% capacity position, so even the oil coming from the oil sump is continuously injecting into the cylinder through the capillary, the high-pressured oil in the cylinder bypasses directly into the suction port, so the piston is kept in its initial position.

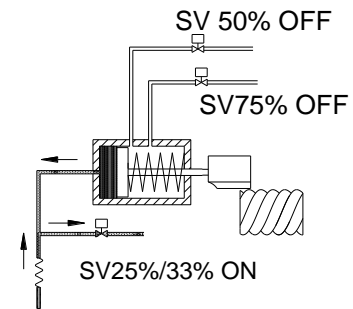

Figure 9 Min% Capacity

※It is strongly recommended to energize SV25%/33% solenoid valve for 1~3 minutes before starting the compressor to ensure the slide valve is in min% position.

b. 50% capacity (omitted for RC2-100, 140,180)

When SV50% solenoid valve is energized by the temperature controller, the high-pressure oil in the oil sump flows into the cylinder due to the closing of min% valve that pushes the piston moving toward the position where a hole at exactly 50% position drains the oil back to the suction side then the piston is held on that position.

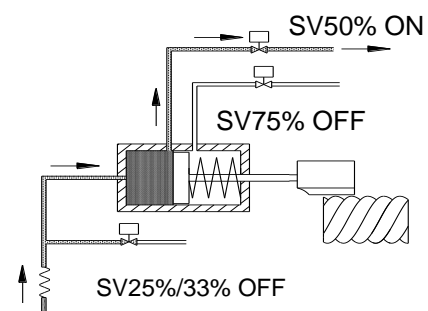

Figure 10 50% Capacity

c. 75%/66% capacity

When SV75%/66% solenoid valve is energized, SV50% solenoid valve will be de-energized simultaneously, the high pressure oil will push the piston toward the position where a hole at exactly 75%/66% position drains the oil back to the suction side and the piston will be held on that position.

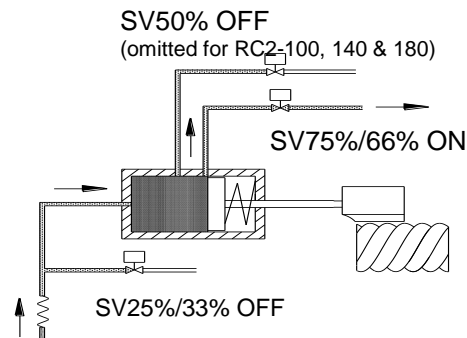

Figure 11 75%/66% Capacity

d. 100% full load

When all of two/three modulation solenoid valves are de-energized, the high-pressure oil flows into the cylinder continuously to push the piston toward the suction side gradually until the slide valve touches the end of the compression chamber and the piston also reaches its dead end entirely where no bypass of compression gas occurred. Therefore, full load is achieved.

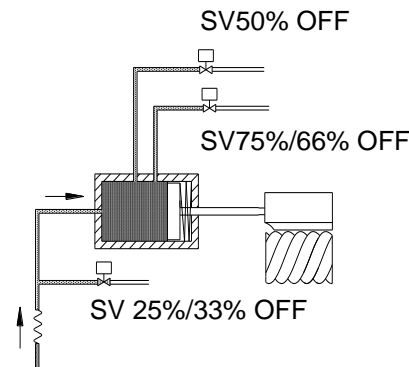

Figure 12 100% (Full load) Capacity

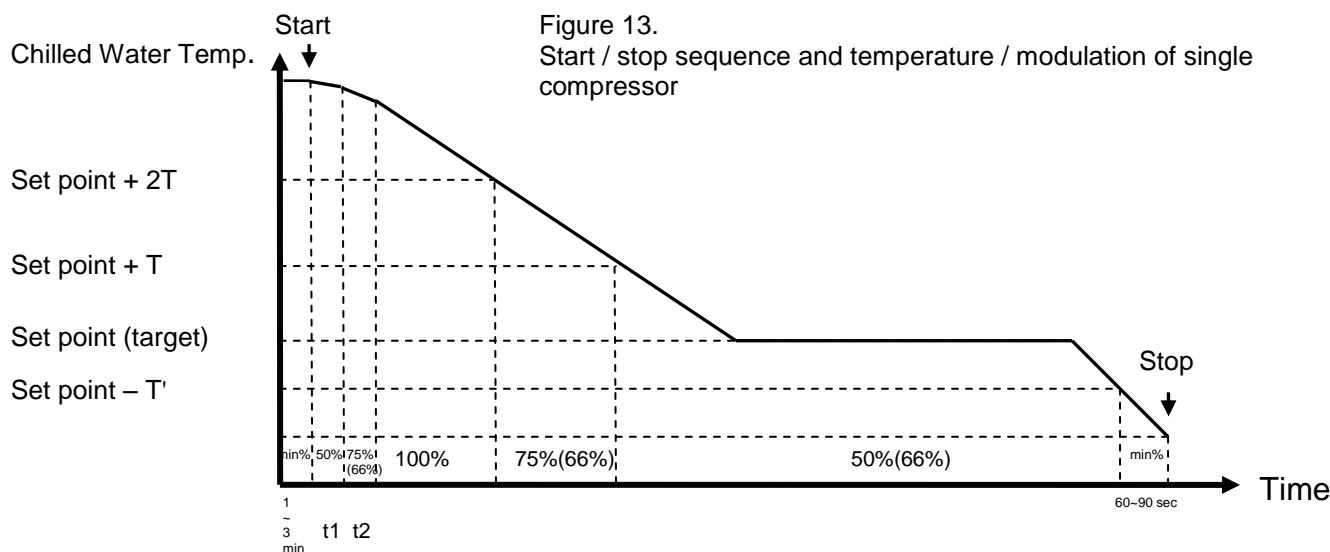

Figure 13. Start / stop sequence and temperature / modulation of single compressor

※ It is strongly recommend to start /stop compressors as per above illustration

Note: 1. Above T & T' should be determined by system designer's experience and end user's application.

2. Above t1 & t2 should be longer than 60 sec as recommended.

3. Capacity control must be kept at min% capacity for 1~3 min before start and for 60~90 sec before stop.

4. Start the compressor at min% and SV50% can be energized right after start.

2.8 Continuous (stepless) capacity control system

In continuous (stepless) capacity control system, solenoid valve SV2 (for loading) and solenoid valve SV1 (for unloading) are equipped to inlet and outlet of piston cylinder respectively. These two solenoid valves are controlled by chiller temperature controller or micro controller so refrigeration capacity can be modulated anywhere within min% ~ 100%. Min% is recommended for start and stop only, not for long-termed operation.

It is very important for any controller to control loading and unloading in stable condition. For a smooth modulation, HANBELL installs a capillary in loading oil line and an additional orifice valve in unloading oil line to avoid too fast loading and unloading.

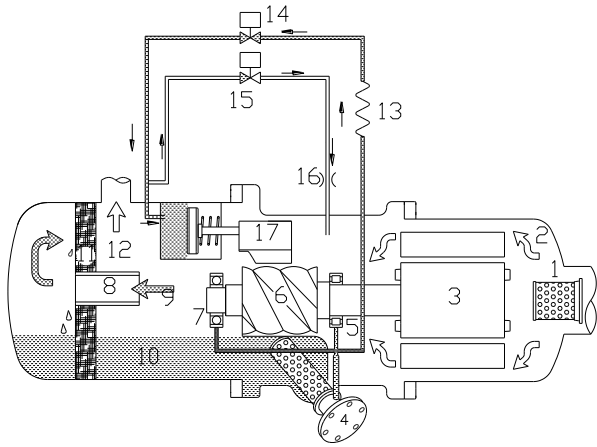

No.	Component	No.	Component	No.	Component
1	Suction filter	7	Discharge bearings	13	Capillary
2	Gas in (low pressure)	8	Oil separator baffle	14	Solenoid valve, SV2
3	Motor	9	Gas out (high pressure with oil)	15	Solenoid valve, SV1
4	Oil filter cartridge	10	Lubricant	16	Orifice
5	Suction bearings	11	Oil separator cartridge	17	Slide valve
6	Male rotor	12	Gas out (high pressure without oil)		

Figure 14 Stepless capacity control

- Note: 1. In continuous (stepless) capacity control system, Hanbell installs two normally closed solenoid valves as standard accessory. If it is necessary to be equipped with other type of solenoid valves, please specify it when placing orders.
2. If customers prefer to remove unloading orifice or equip with loading orifice for system application, please specify it when placing orders
3. Normally opened solenoid valve SV2 (for loading) is an option.

	SV1(NC) Standard	SV2(NC) Standard	SV2(NO) Option
Start	energized	not energized	energized
Loading	not energized	energized	not energized
Unloading	energized	not energized	energized
Stable	not energized	not energized	energized

Capacity Modulation	NC SV2 (Standard)	NO SV2 (Option)
<p>a. Loading</p> <p>Standard: When NC SV2 is energized but NC SV1 is not energized, oil will be injected continuously into piston cylinder and will not bypass through NC SV1 so compressor keeps loading.</p> <p>Option: When both NO SV2 and NC SV1 are not energized, oil will be injected continuously into piston cylinder and will not bypass through NC SV1 so compressor keeps loading.</p>	<p style="text-align: center;">LOADING</p>	<p style="text-align: center;">LOADING</p>
<p>b. Unloading</p> <p>Standard: When NC SV1 is energized but NC SV2 is not energized, oil inside piston cylinder will bypass to suction port through NC SV1.</p> <p>Option: When both NO SV2 and NC SV1 are energized, oil inside piston cylinder will bypass to suction port through NC SV1.</p>	<p style="text-align: center;">UNLOADING</p>	<p style="text-align: center;">UNLOADING</p>

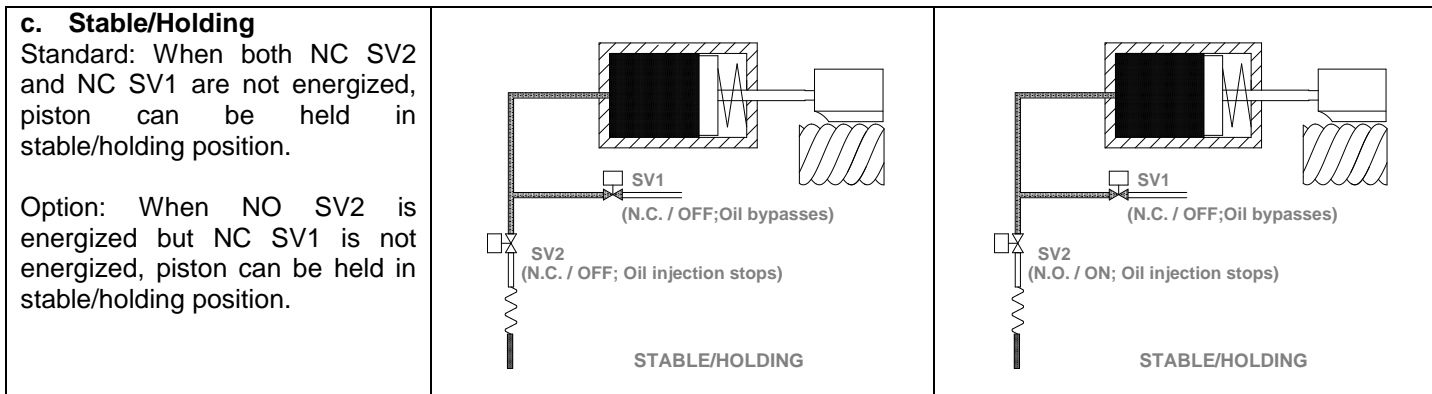

Continuous /stepless capacity control principle

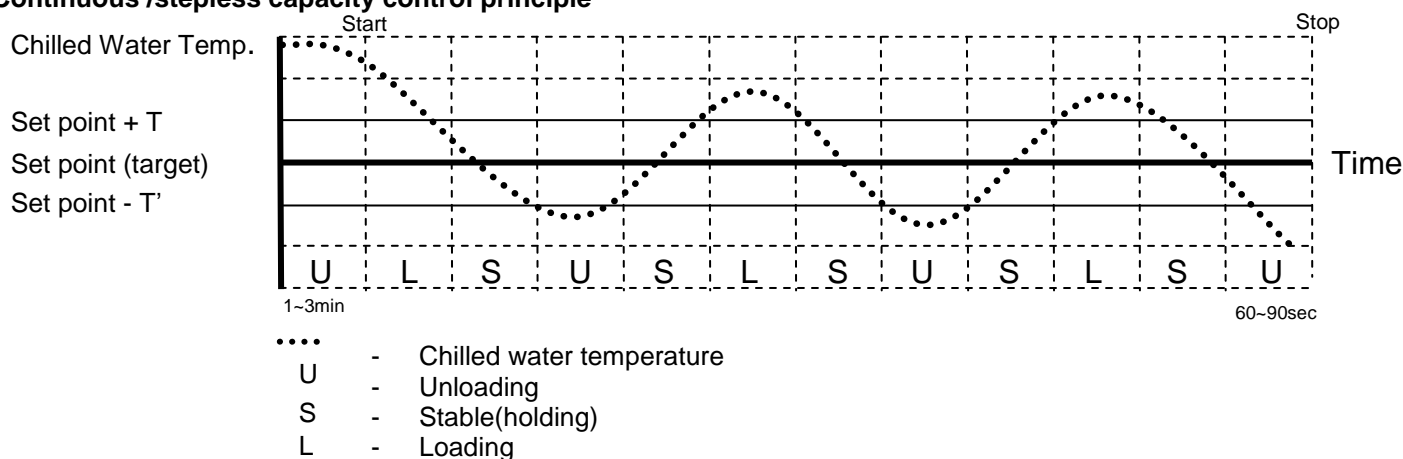

Note: 1. Above T. & T' should be determined by system designer's experience and end user's application.
 2. Capacity control must be kept at unloading for 1~3 min before start and for 60~90 sec before stop.

Loading/unloading functions

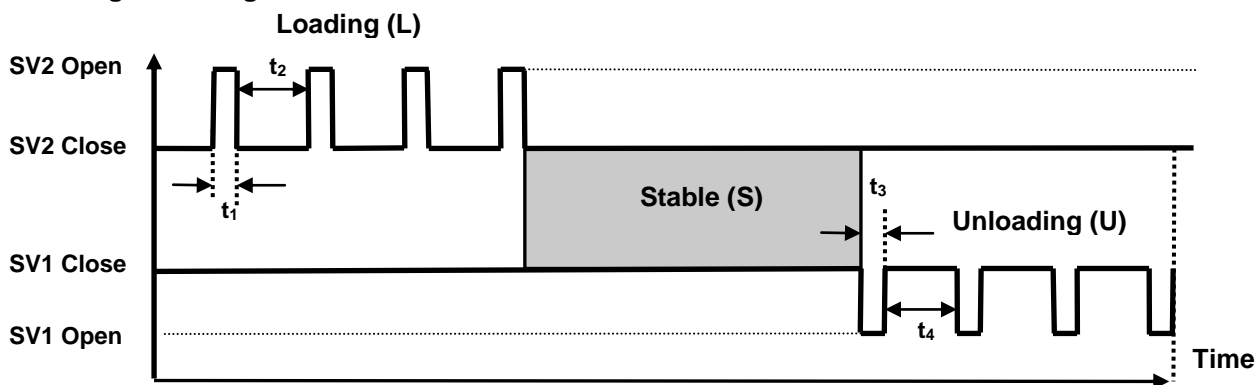

Figure 15 Loading and unloading functions

t₁, t₃: Pulse time 1 ~ 1.5 seconds
t₂, t₄: Pause time 15 ~ 20 seconds

2.9 Dual capacity control system (optional)

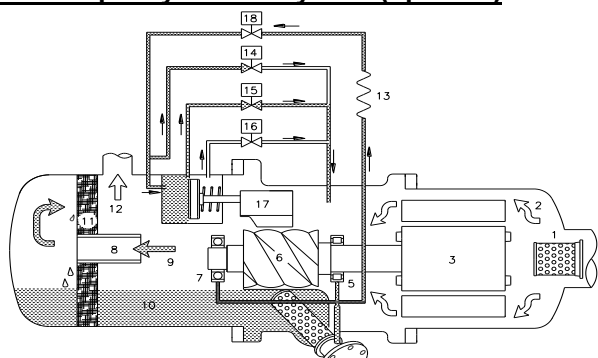

Figure 16 Dual capacity control

No.	Component	No.	Component	No.	Component
1	Suction filter	7	Discharge bearings	13	Capillary
2	Gas in (low pressure)	8	Oil separator baffle	14	Solenoid valve
3	Motor	9	Gas out (high pressure with oil)	15	Solenoid valve
4	Oil filter cartridge	10	Lubricant	16	Solenoid valve
5	Suction bearings	11	Oil separator cartridge	17	Slide valve
6	Male rotor	12	Gas out (high pressure without oil)	18	Solenoid valve

Hanbell can provide compressors with capacity as shown in the figure 16, and its control logic is the same as those shown in chapter 2.7 and 2.8.



2.10 Compressor volume ratio (Vi)

The volume ratio (**Vi**) of the compressor can be defined as the ratio of suction volume to discharge volume in the compressor. The smaller the concavity of slide valve in the discharge end, the larger the volume ratio. The volume ratio directly affects the internal compression ratio (**Pi**). Low **Vi** corresponds to low **Pi** and high **Vi** corresponds to high **Pi**. In the equation below, in order to prevent over or under compression, the system compression ratio (**CR**) should be equal to compressor's internal compression ratio (**Pi**). Please refer to P-V (pressure – volume) diagram below to figure out this relation.

$$\begin{aligned} CR &= P_d/P_s \\ P_i &= V_i^k \\ V_i &= V_s/V_d \end{aligned}$$

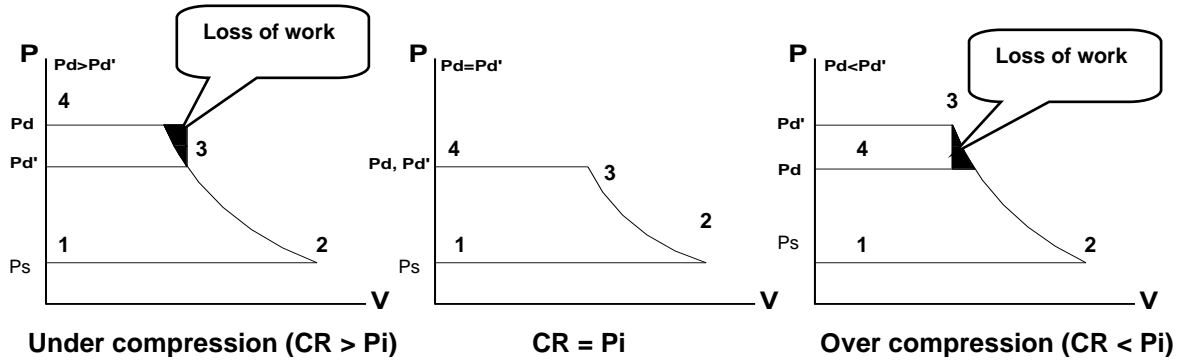

Figure 17 P-V Diagram

Where: **CR:** system compression ratio
Vi: internal volume ratio
Pd': discharge pressure (absolute pressure)
Vs: suction volume

Pi: internal compression ratio
Pd: system pressure (absolute pressure)
Ps: suction pressure (absolute pressure)
Vd: discharge volume **K:** refrigerant specific heat ratio

2.11 Application limits

Application limits of the compressor vary significantly with the type of refrigerant used. The operating limits shown below are based on saturated suction and discharge operating conditions, for continuous operation over extended periods of time. It is important to operate within these limits to maintain proper compressor life. Operating at extra low saturated suction temperature, may cause oil management and motor cooling problems, and operating at extra high saturated condensing temperature will shorten the compressor life due to insufficient motor and compressor chamber cooling.

a. Application limits of RC2-100~RC2-930 are described on the respective refrigerant charts.

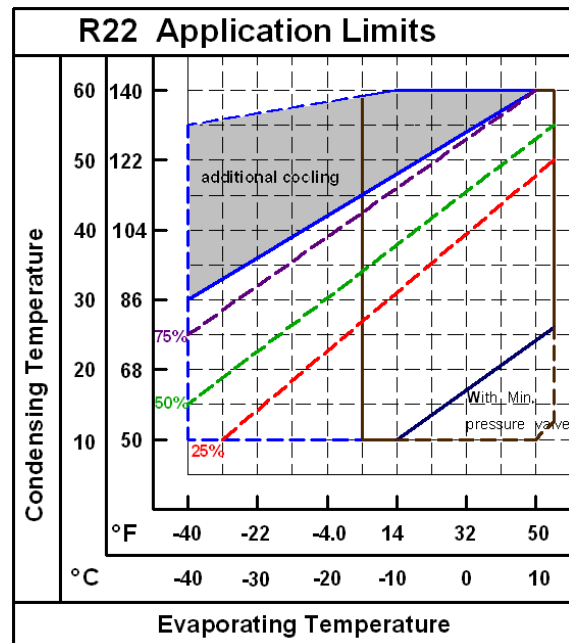
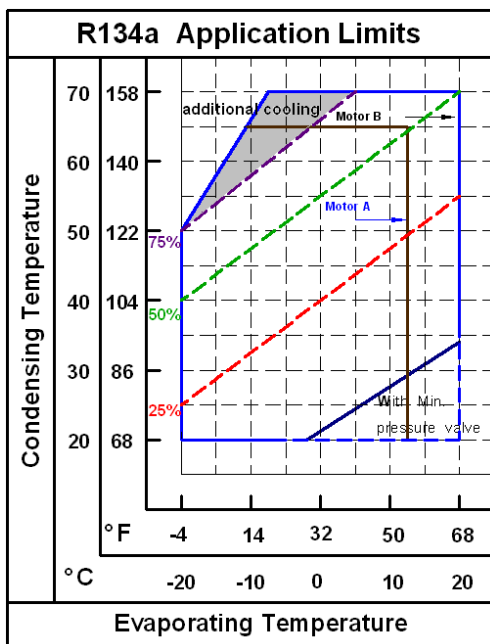

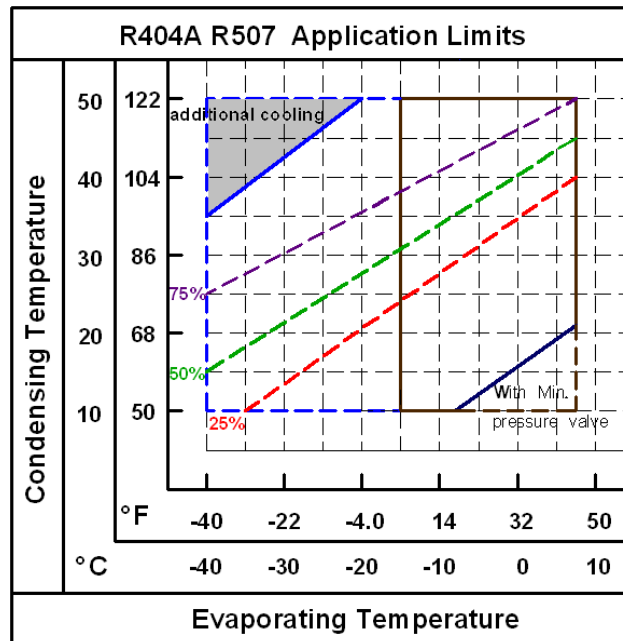
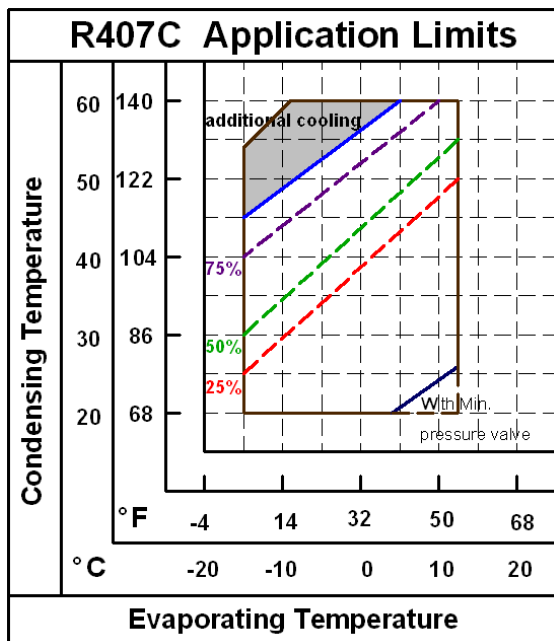

R1234yf, R513A, R450A

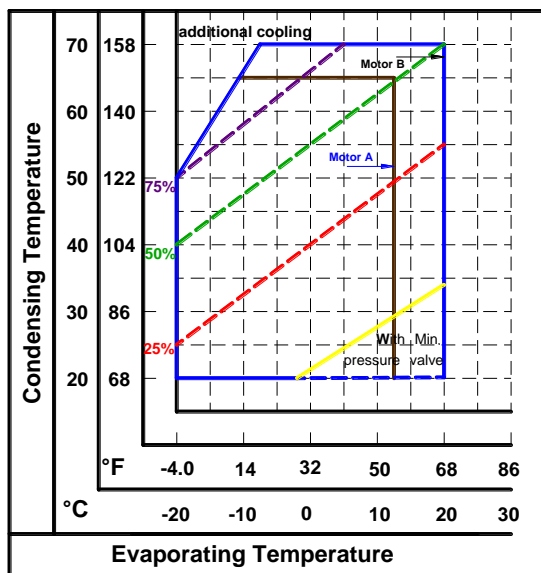

R1234ze

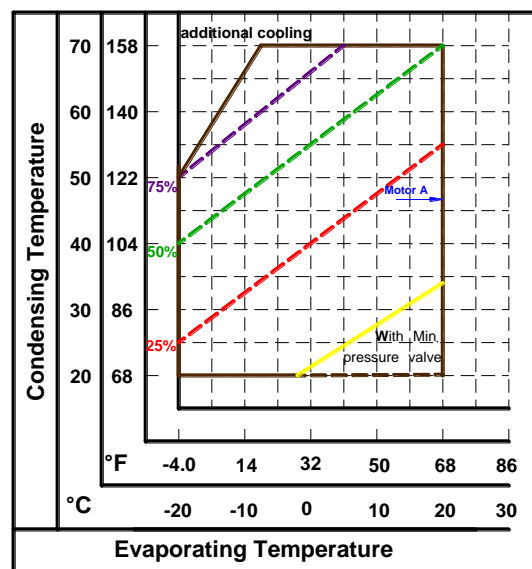

b. Application limits of of RC2-1020~RC2-1530 are described on the respective refrigerant charts.

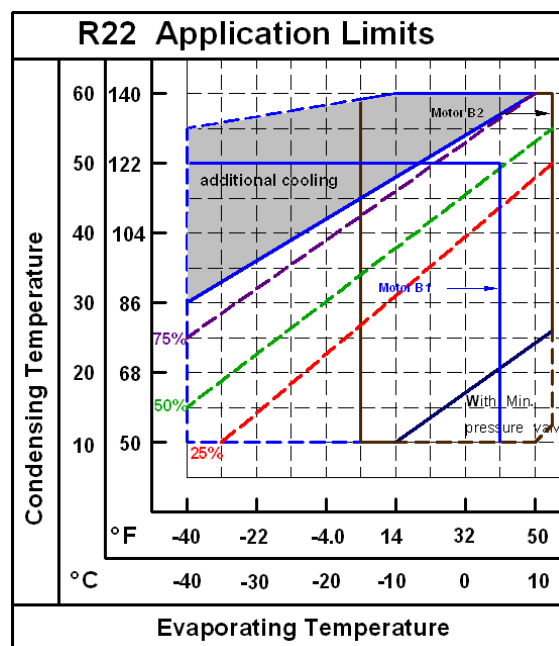
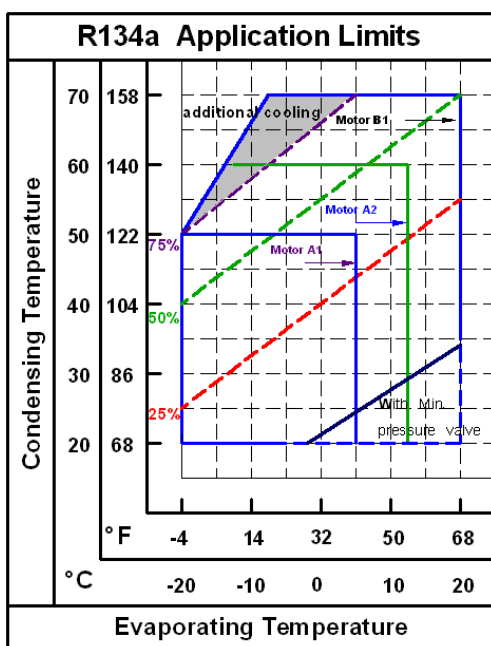

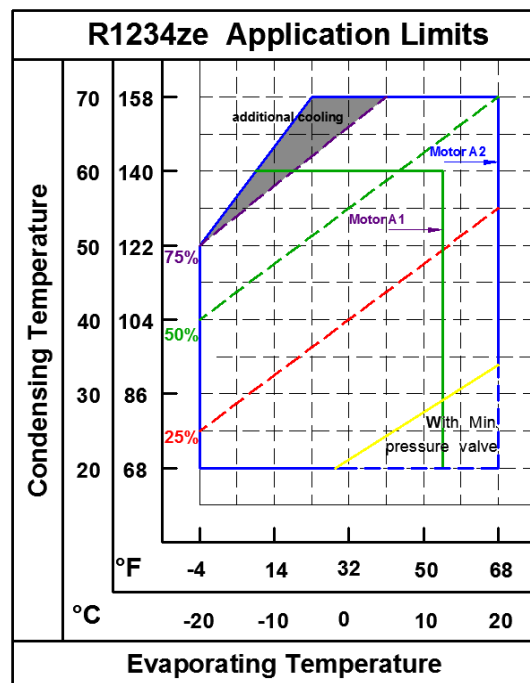
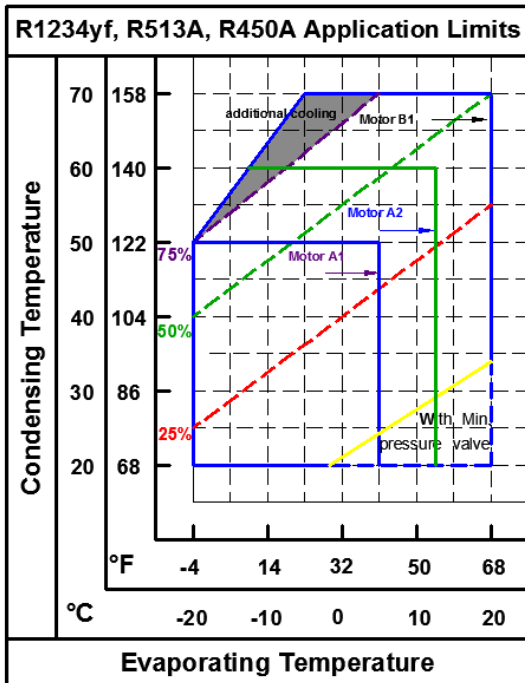
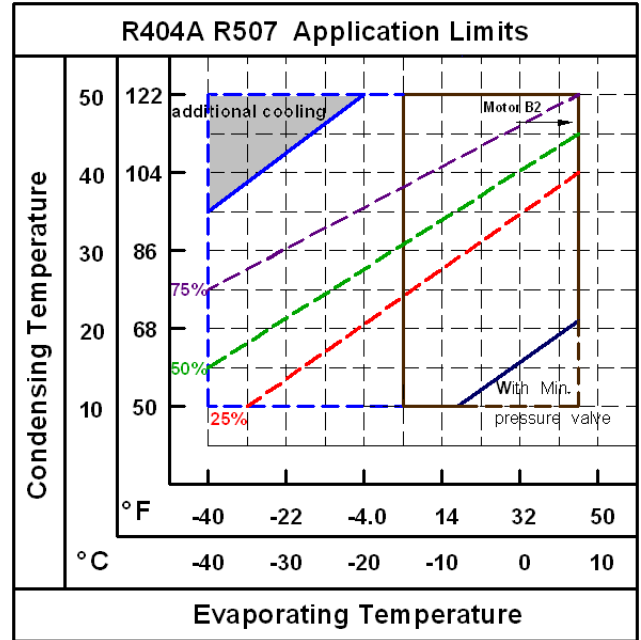
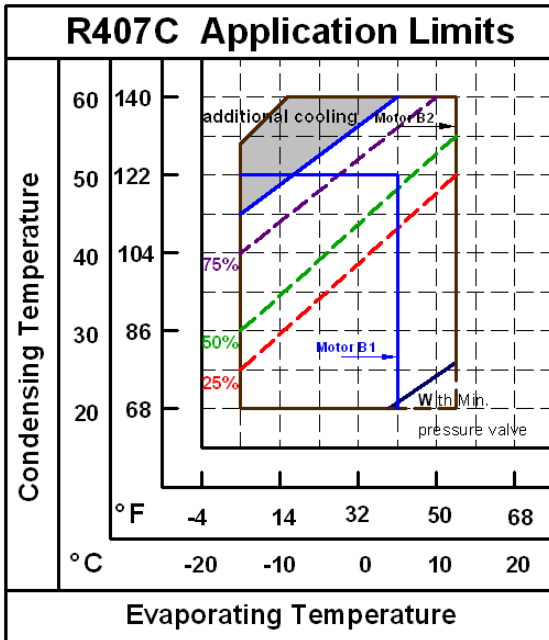

Note:

1. When Hanbell screw compressor operate in partial or full load within limits, temperature of motor coil and discharge will rise concurrently. In order to keep the safe running of compressor continuously, Hanbell recommend application of the following additional cooling devices:

- (1) Oil cooler or (2) Liquid injection to chamber or (3) Liquid injection to motor.

Please refer to Hanbell selection software for application of additional cooling system.

Hanbell recommends monitoring oil pressure differential and keep it $4 \text{ kg/cm}^2\text{G}$ over the suction pressure for adequate seal, lubrication and capacity control by pressure differential switch passively or by additional oil pump or minimum pressure valve actively. Especially under operation conditions with low condensing temperature and high evaporating temperature like application in flooders water-cooled chillers, high-low pressure difference tends to be less than $4 \text{ kg/cm}^2\text{G}$, installation of oil pump is recommended to ensure regular oil pressure.

Contact with Hanbell to verify potential operating conditions outside the limits shown.

2. If compressors run continuously at partial load below 50%, failure of motor coils might happen due to insufficient cooling. Therefore, Hanbell emphasizes installation of liquid injection system to motor to make sure adequate cooling of motor coils for safe running of compressors. According to EN12900, suction superheat is 10°k and liquid sub-cooling is 0°k .

3. Lubricants

The main functions of lubrication oil in screw compressors are lubrication, internal sealing, cooling and capacity control. Positive oil pressure in the cylinder pushes the piston together with the slide valve that is connected by a piston rod to move forward and backward in the compression chamber. The design of positive pressure differential lubrication system makes RC2 series normally omit an extra oil pump which is necessary for reciprocating compressors. However, in some special applications, it is still necessary to install an extra oil pump to screw compressors for safety.

Bearings used in RC2 series compressors require a small and steady quantity of oil for lubrication. Oil injection into the compression chamber creates a film of oil for sealing in the compression housing to increase efficiency and also can dissipate part of compression heat. In order to separate oil from refrigerant gas, an oil separator is required to ensure the least amount of oil carried into the system.

Please pay more attention to the oil temperature, which is crucial to compressor bearings' life. Oil is with much lower viscosity at high temperatures. Too low viscosity of oil will result in poor lubrication and heat dissipation in the compressor. Viscosity is recommended to keep over 10mm²/s at any temperatures for oil. Oil temperature in the oil sump should be kept above the saturated condensing temperature to prevent refrigerant migration into lubrication system. Oil has a higher viscosity in low ambient temperature circumstances. When viscosity is too high, slow flow speed of oil into the cylinder may result in too slow loading of the compressor. To solve this problem, use of oil heaters can warm up oil before starting.

If the compressor operates under critical operating conditions, an extra oil cooler is required – please refer to Hanbell selection software for the required capacity and oil flow of the extra oil cooler. High-viscosity oil is recommended to apply in high operating conditions because high discharge temperature will make viscosity of oil lower. Oil return from the evaporator may be insufficient in refrigeration systems, flooded chillers...etc., in which it's difficult for oil to be carried back and it may cause oil loss in the compressor. If the system encounters the oil return problem then an extra 2nd oil separator is recommended to be installed between the compressor discharge tube and condenser.

Each of HANBELL RC2-230 ~ RC2-930 compressors is equipped with two oil sight glasses as a standard (the second sight glass is optional for the models RC2-100 ~ RC2-200), one is the high-level sight glass, and the other is the low-level sight glass (RC2-230~RC2-510, RC2-580 and RC2-1020~RC2-1530) or internal oil line sight glass (RC2-550 & RC2-620~RC2-930). The function of internal oil line sight glass is to monitor lubricant flow to capacity control system and bearings. While reverse running, it is unable to see the oil flow via sight glass. The normal oil level in the compressor oil sump should be maintained above the top of the low-level sight glass and in the middle level of high-level sight glass when compressor is running. It is strongly recommended to install the oil level switch (optional accessory) to prevent the failure results from lose of oil.

3.1 Lubricants table

Applicable oil types (R22)

SPECIFICATION	UNITS	HBR -B10	HBR -A02	HBR -A04	HBR -B09	HBR -B02	HBR -B01	
COLOR, ASTM		1.5	L1.0	L1.0	–	–	–	
SPECIFIC GRAVITY		0.883	0.914	0.925	0.95	1.01	1.05	
VISCOSITY	40°C	mm ² /s (cSt)	56.0	54.5	96.5	175	168	298
	100°C		7.0	6.07	8.12	16.5	20.2	32.0
FLASH POINT	°C	220	188	198	265	290	271	
POUR POINT	°C	-40	-35	-25	-30	-43	-35	
T.A.N	MgKOH/g	0.01	0.00	0.01	–	–	–	
COPPER STRIP 100°C/3hr		1a	1a	1a	–	–	–	
MOISTURE	ppm	15	20	20	–	–	–	
FLOC POINT	°C	-75	-45	-35	–	–	–	
DIELECTRIC STRENGTH (2.5mm)	KV	75	50	50	46.6	–	–	

Applicable oil types (R134a, R404A, R407C)

SPECIFICATION	UNITS	HBR -B05	HBR -B08	HBR -B09	HBR -B04	
COLOR, ASTM		–	–	–	–	
SPECIFIC GRAVITY		0.945	0.94	0.95	0.95	
VISCOSITY	40°C	mm ² /s (cSt)	64	131	175	215.9
	100°C		8.9	14.53	16.5	20.8
FLASH POINT	°C	266	254	265	271	
POUR POINT	°C	-43	-36.5	-30	-25	
T.A.N	mg KOH/g	–	–	–	–	
COPPER STRIP 100°C/3hr		–	–	–	–	
MOISTURE	ppm	–	–	–	–	
FLOC POINT	°C	–	–	–	–	
DIELECTRIC STRENGTH 2.5mm	KV	–	–	46.6	–	

Note: For other applicable oil types (HFO Refrigerant), please consult HANBELL firstly for approval.



3.2 Pre-cautions of changing oil

1. Use only qualified oil and do not mix different brands of oil together. Selection of oil should match characteristics of the refrigerant used. Some types of synthetic oil are incompatible with mineral oil. Oil remained in the compressor should be totally cleaned up in the system before charging different brands of oil. Charge the compressor with oil for the first start and then change it into new oil again to ensure that there's no mix at all.
2. When using polyester oil for chiller systems, please make sure not to expose oil to the atmosphere for prevention of change in its property. Therefore, it is necessary to vacuum the system completely when installing the compressor.
3. In order to ensure no moisture inside the system, it is suggested to clean the system by charging it with dry Nitrogen and then vacuum it repeatedly as long as possible.
4. It is a must to change the oil in motor burned out case, because acid debris may still remain inside the system. Please follow the procedures mentioned above to change oil in the system. Check acidity of oil after 72 hours of operation and then change it again until acidity of oil becomes normal.
5. Please contact Hanbell local distributors/agents for selection of oil.

3.3 Oil change

1. Change oil periodically: Check lubrication oil every 10,000 hours of continuous running. For the first operation of the compressor, it is recommended to change the oil and clean the external oil filter after running 2,000 hours. Check the system whether clean or not and then change oil every 20,000 hours or after 3 years' continuous running while the system operates in good condition.
2. Avoid clogging in oil filter with debris or swarf which may cause failure in bearings. An optional oil pressure differential switch is recommended to be installed. The switch will trip when the oil pressure differential between the primary and secondary sides reaches the critical point and then the compressor will automatically shut down to prevent the bearings from damage due to oil loss.

4. Compressor handling and installation

4.1 Compressor lifting

Each HANBELL screw compressor has been carefully tested at the factory and every precautionary measures have been taken to make sure that compressors will keep in perfect condition when reach customers' work. After the compressor arrives at your warehouse, please check if its crate is kept in good condition and check all the compressor accessories with shipping documents to see if there is any discrepancy.

When lifting the compressor, it is recommended to use a steel chain or steel cable which can be used for loading capacity of 3000kgf as shown in the figure below. Make sure that chains, cables or other lifting equipments are properly positioned to protect the compressor and its accessories from damaging. Keep the compressor in horizontal position when lifting, and prevent it from crashing or falling on the ground, hitting the wall or any other accident that may damage it or its accessories.

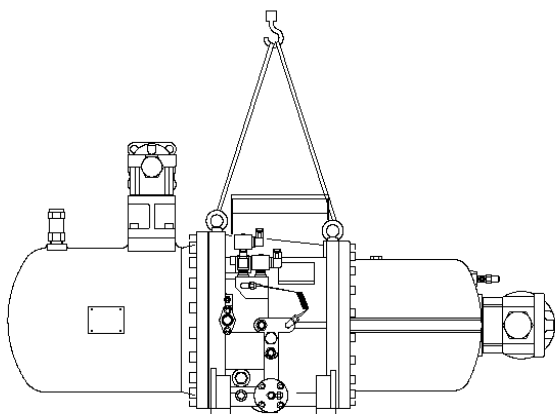

Figure 18 Lift the compressor with steel chain or steel cable

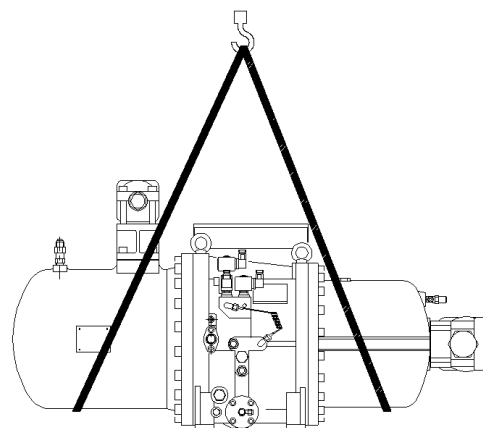

Figure 19 Lift the compressor with safety ropes

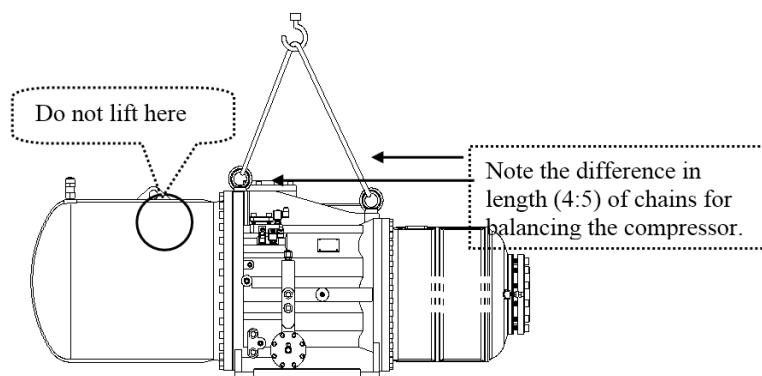

Figure 21 RC2-1270 and RC2-1530 lifting instruction

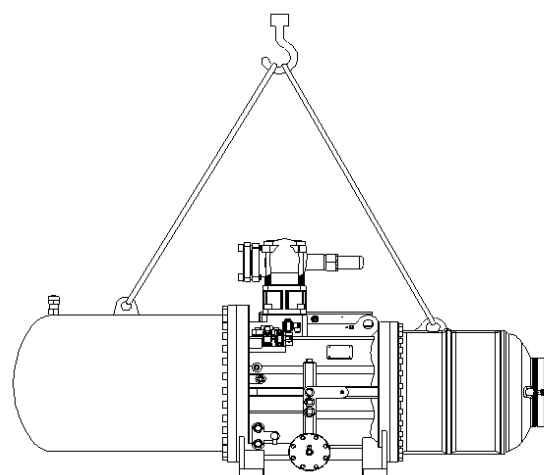

Figure 20 RC2-1020 and RC2-1130 lifting instruction

Note: For Model RC2-1270 and RC2-1530, please lift the compressor as instruction above. Apply the two eyebolts on the top of chamber to lift the compressor for installation. The opening on the top of oil separator is only for dismantling oil separator during maintenance or overhauling. Please do not lift the compressor by this opening.



4.2 Mounting the compressor

The installation of the compressor in the refrigeration system should be accessible and make sure that the chiller base or site is far enough from the heat source to prevent heat radiation. The compressor should also be installed as close as possible to the electrical power supply for easier connection and must keep good ventilation and low humidity condition in the site. Make sure that the frame or supporter is strong enough to prevent excessive vibration and noise while the compressor is running and must reserve enough space for compressors' future overhauling work.

The compressor must be installed horizontally and in order to prevent excessive vibration transferred by the structure and piping of the chiller while in operation, the cushion or anti-vibration pad should be installed. The installation of the anti-vibration pad is shown in Figure 22. The screws should only be tightened until slight deformation of the rubber pad is visible.

※It is strongly recommended to position the compressor higher than the evaporator

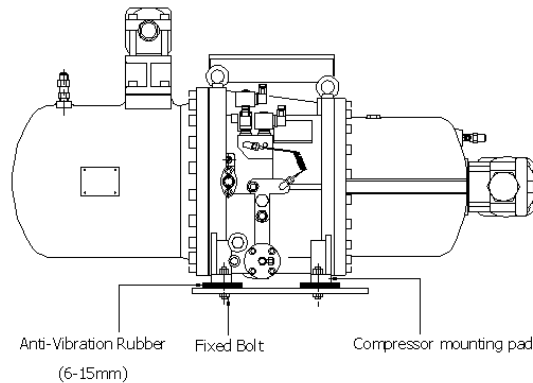

Figure 22 Installation of anti-vibration pad

Suggestions on piping works

The unsuitable piping works done to the compressor could cause abnormal vibration and noise that might damage the compressor. Take notice of the following pointers to prevent this situation from happening:

1. Cleanliness of the system should be kept after welding the piping to avoid any swarf or debris contained inside the system as it may cause serious damage to the compressor during operation.

2. In order to reduce the vibration on the piping tubes, it is recommended to use copper tube to be the suction and discharge piping tubes. Copper tubes are better to minimize the vibration in the piping while the compressor is in operation. In case steel tubes are used in piping system, the suitable welding works are very important to avoid any stress in the piping. This inner stress can cause harmonic vibration and noise that can reduce the life of the compressor. If a large-caliber copper tube is not easily accessible and a steel tube is used instead in suction port, Hanbell also recommends the use of a copper tube in discharge port to best minimize abnormal vibration and noise.

3. Remove the oxidized impurities, swarf or debris caused by welding in the piping tubes. If these materials fall into the compressor, the oil filter might be clogged and result in the malfunction of lubrication system, bearings and capacity control system.

4. The material of suction and discharge flange bushing is forged steel and it can be welded directly with piping connectors. After welding the flange bushing and pipes, it must be cooled down by ambient air. Do not use water to cool it down because water quenching is prohibited.

Installing the compressor in a sloping position

Figure 23 shows a 15° limit of oblique angle for installation of compressor. In case the oblique angle is higher than the limit, compressor will be shut down easily. For special applications like the installation in ships, fishing boats, etc..., where the oblique angle might exceed the limit, external oil separators, oil tanks and related accessories are recommended to be installed. Please contact HANBELL or local distributors for further layout recommendation.

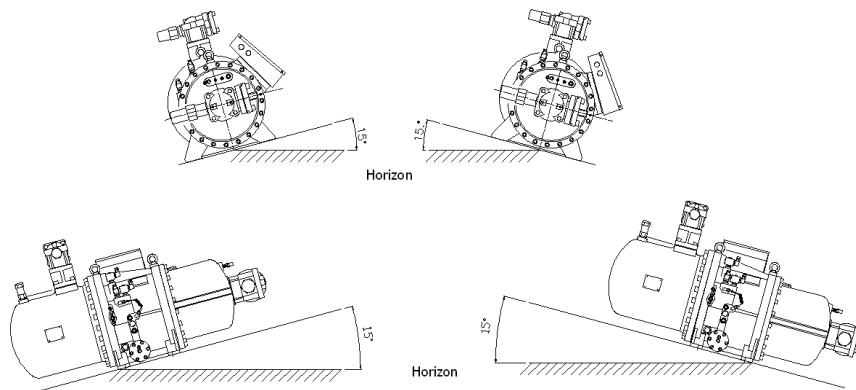
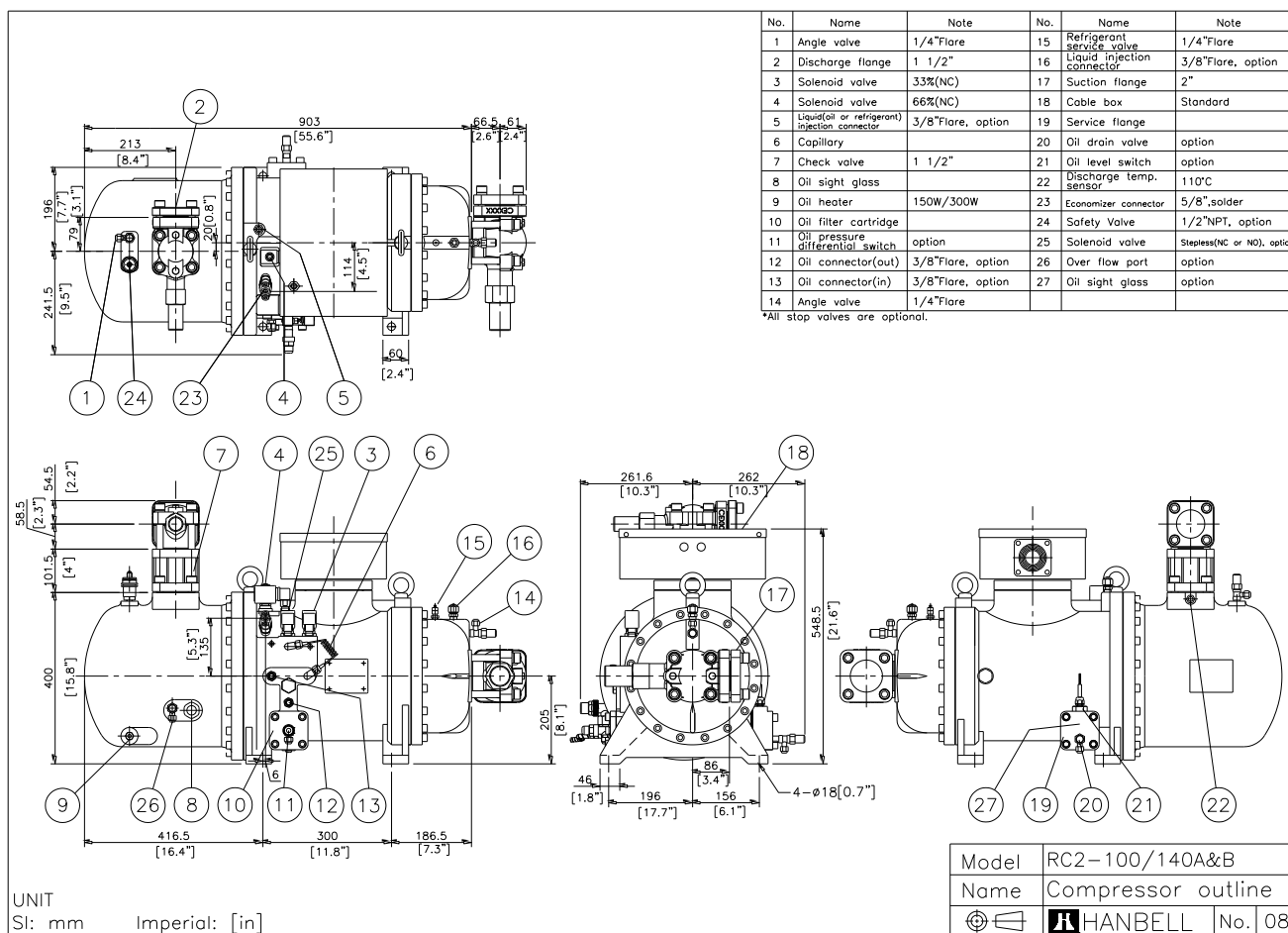

Figure 23 Limits of oblique angle for the installation of the compressor

4.3 RC2 compressor outline drawings

1. RC2-A outline drawings





No.	Name	Note	No.	Name	Note
1	Angle valve	1/4"Flare	15	Refrigerant service valve	1/4"Flare
2	Discharge flange	1 1/2"	16	Liquid injection connector	5/8"Flare, option
3	Solenoid valve	33%(NC)	17	Suction flange	2 1/2"
4	Solenoid valve	66%(NC)	18	Cable box	Standard
5	Liquid(oil or refrigerant) injection connector	3/8"Flare, option	19	Service flange	
6	Capillary		20	Oil drain valve	option
7	Check valve	1 1/2"	21	Oil level switch	option
8	Oil sight glass		22	Discharge temp. sensor	110°C
9	Oil heater	150W/300W	23	Economizer connector	5/8",solder
10	Oil filter cartridge		24	Safety Valve	1/2"NPT, option
11	Oil pressure differential switch	option	25	Solenoid valve	Stepless(NC or NO),option
12	Oil connector(out)	3/8"Flare, option	26	Over flow port	option
13	Oil connector(in)	3/8"Flare, option	27	Oil sight glass	option
14	Angle valve	1/4"Flare			

*All stop valves are optional.

Model	RC2-180A/B
Name	Compressor outline
	HANBELL No. 08

UNIT
SI: mm Imperial: [in]

No.	Name	Note	No.	Name	Note
1	Angle valve	1/4"Flare	16	Angle valve	1/4"Flare
2	Discharge flange	1 1/2"	17	Refrigerant service valve	1/4"Flare
3	Solenoid valve	50%(NC)	18	Solenoid valve	Stepless(NC or NO),option
4	Solenoid valve	75%(NC)	19	Liquid injection connector	5/8"Flare, option
5	Solenoid valve	25%(NC)	20	Suction flange	2 1/2"
6	Liquid(oil or refrigerant) injection connector	3/8"Flare, option	21	Cable box	Standard
7	Capillary		22	Service flange	
8	Check valve	1 1/2"	23	Oil drain valve	option
9	Oil sight glass	Low side	24	Oil level switch	option
10	Oil heater	150W/300W	25	Discharge temp. sensor	110°C
11	Oil filter cartridge		26	Safety Valve	1/2"NPT,option
12	Oil pressure differential switch	Connector, option	27	Economizer part	5/8", solder
13	Oil connector(out)	5/8"Flare, option	28	Over flow port	option
14	Stop pin	option			
15	Oil connector(in)	5/8"Flare, option			

*All stop valves are optional.

Model	RC2-200A
Name	Compressor outline
	HANBELL No. 06

UNIT
SI: mm Imperial: [in]

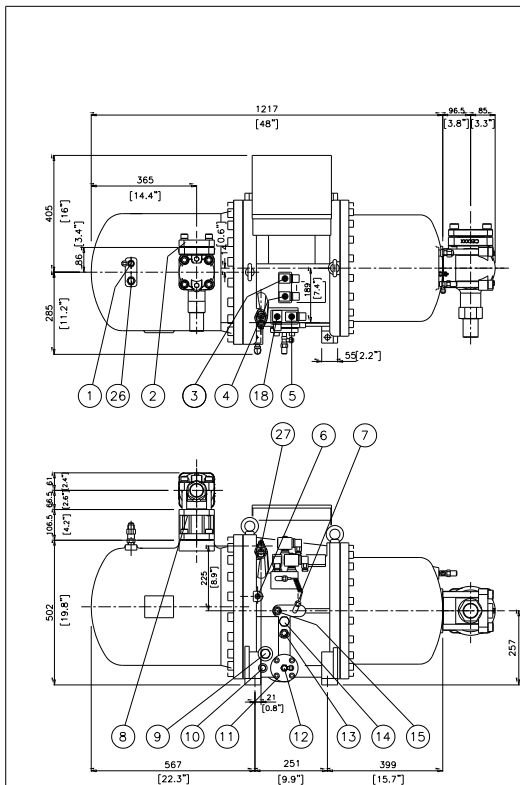

No.	Name	Note	No.	Name	Note
1	Angle valve	1/4"Flare	16	Angle valve	1/4"Flare
2	Discharge flange	2"	17	Refrigerant service valve	1/4"Flare
3	Solenoid valve	50%(NC)	18	Solenoid valve	Stepless(NC or NO), option
4	Solenoid valve	75%(NC)	19	Liquid injection connector	5/8"Flare, option
5	Solenoid valve	35%(NC)	20	Suction flange	3"
6	Liquid(oil or refrigerant) injection connector	3/8"Flare, option	21	Cable box	Standard
7	Capillary		22	Service flange	
8	Check valve	2"	23	Oil drain valve	option
9	Oil sight glass	Low side	24	Oil level switch	option
10	Oil heater	150W/300W	25	Discharge temp. sensor	110°C
11	Oil filter cartridge		26	Safety Valve	1/2"NPT,option
12	Oil pressure differential switch	Connector, option	27	Economizer port	5/8", solder
13	Oil connector(out)	5/8"Flare, option	28	Oil sight glass	High side
14	Stop pin	option	29	Over flow port	option
15	Oil connector(in)	5/8"Flare, option			

*All stop valves are optional

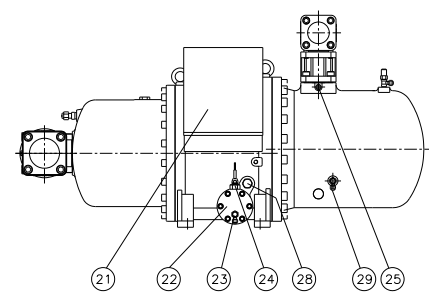
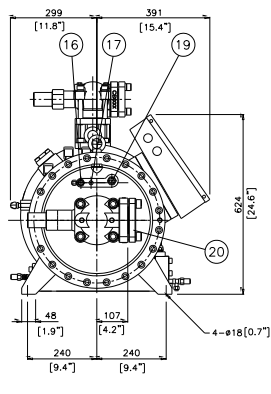

UNIT
SI: mm Imperial: [in]

Model	RC2-230A/B
Name	Compressor outline
	No. 06

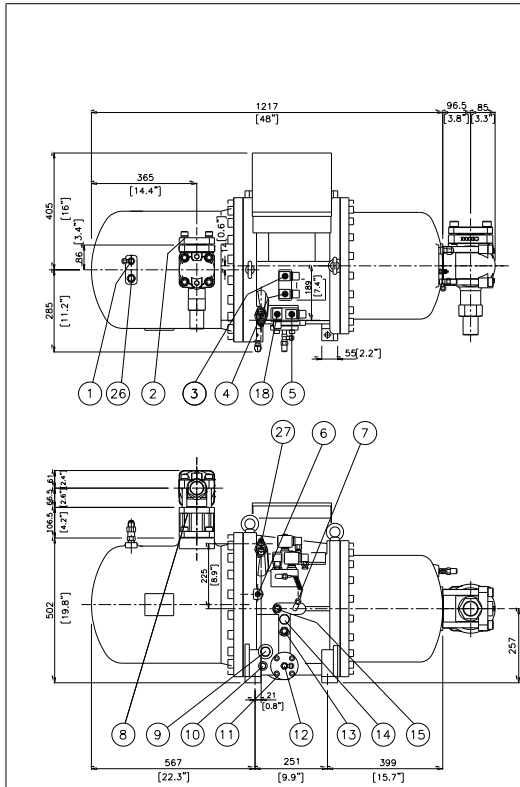

No.	Name	Note	No.	Name	Note
1	Angle valve	1/4"Flare	16	Angle valve	1/4"Flare
2	Discharge flange	2"	17	Refrigerant service valve	1/4"Flare
3	Solenoid valve	50%(NC)	18	Solenoid valve	Stepless(NC or NO), option
4	Solenoid valve	75%(NC)	19	Liquid injection connector	5/8"Flare, option
5	Solenoid valve	25%(NC)	20	Suction flange	3"
6	Liquid(oil or refrigerant) injection connector	3/8"Flare, option	21	Cable box	Standard
7	Capillary		22	Service flange	
8	Check valve	2"	23	Oil drain valve	option
9	Oil sight glass	Low side	24	Oil level switch	option
10	Oil heater	150W/300W	25	Discharge temp. sensor	110°C
11	Oil filter cartridge		26	Safety Valve	1/2"NPT,option
12	Oil pressure differential switch	Connector, option	27	Economizer port	5/8", solder
13	Oil connector(out)	5/8"Flare, option	28	Oil sight glass	High side
14	Stop pin	option	29	Over flow port	option
15	Oil connector(in)	5/8"Flare, option			

*All stop valves are optional

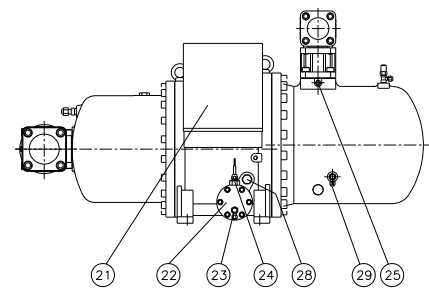
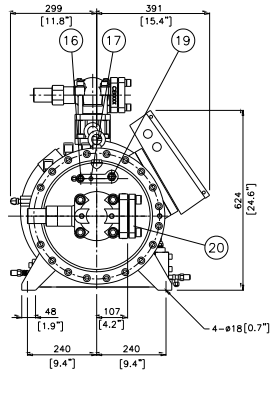

UNIT
SI: mm Imperial: [in]

Model	RC2-260A/B
Name	Compressor outline
	No. 06

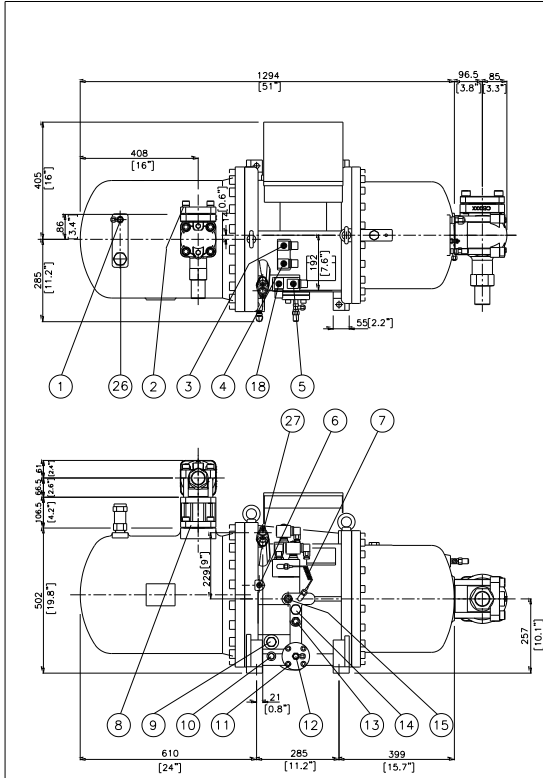

No.	Name	Note	No.	Name	Note
1	Angle valve	1/4"Flare	16	Angle valve	1/4"Flare
2	Discharge flange	2"	17	Refrigerant service valve	1/4"Flare
3	Solenoid valve	50%(NC)	18	Solenoid valve	Stepless(NC or NO), option
4	Solenoid valve	75%(NC)	19	Liquid injection connector	5/8"Flare, option
5	Solenoid valve	25%(NC)	20	Suction flange	3"
6	Liquid(oil or refrigerant) injection connector	3/8"Flare, option	21	Cable box	Standard
7	Capillary		22	Service flange	
8	Check valve	2"	23	Oil drain valve	option
9	Oil sight glass	Low side	24	Oil level switch	option
10	Oil heater	150W/300W	25	Discharge temp. sensor	110°C
11	Oil filter cartridge		26	Safety Valve	1"NPT,option
12	Oil pressure differential switch	Connector, option	27	Economizer part	7/8", solder
13	Oil connector(out)	5/8"Flare, option	28	Oil sight glass	High side
14	Stop pin	option	29	Over flow port	option
15	Oil connector(in)	5/8"Flare, option			

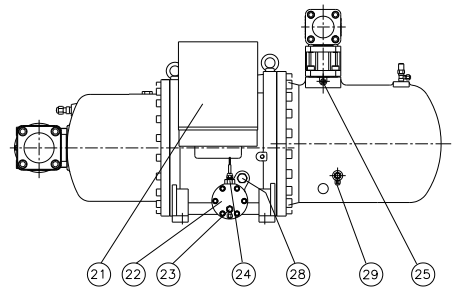
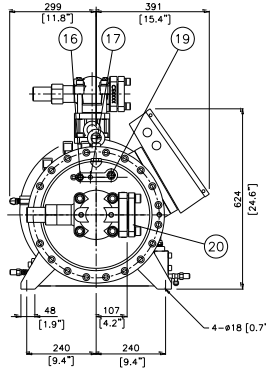

Model	RC2-300/320A
Name	Compressor outline
	No. 06

UNIT
SI: mm Imperial: [in]

No.	Name	Note	No.	Name	Note
1	Angle valve	1/4"Flare	16	Angle valve	1/4"Flare
2	Discharge flange	2"	17	Refrigerant service valve	1/4"Flare
3	Solenoid valve	50%(NC)	18	Solenoid valve	Stepless(NC or NO), option
4	Solenoid valve	75%(NC)	19	Liquid injection connector	5/8"Flare, option
5	Solenoid valve	35%(NC)	20	Suction flange	3"
6	Liquid(oil or refrigerant) injection connector	3/8"Flare, option	21	Cable box	Standard
7	Capillary		22	Service flange	
8	Check valve	2"	23	Oil drain valve	option
9	Oil sight glass	Low side	24	Oil level switch	option
10	Oil heater	150W/300W	25	Discharge temp. sensor	110°C
11	Oil filter cartridge		26	Safety Valve	1"NPT,option
12	Oil pressure differential switch	Connector, option	27	Economizer part	7/8", solder
13	Oil connector(out)	5/8"Flare, option	28	Oil sight glass	High side
14	Stop pin	option	29	Over flow port	option
15	Oil connector(in)	5/8"Flare, option			

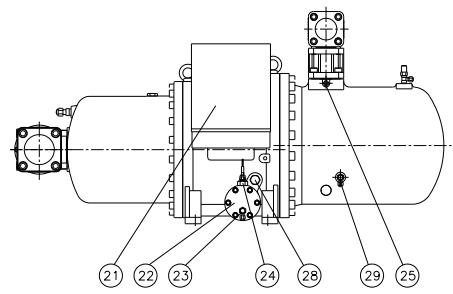
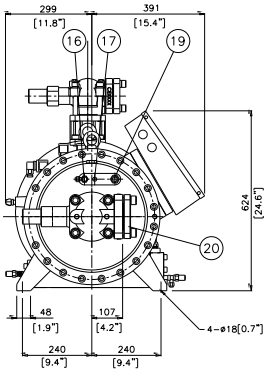
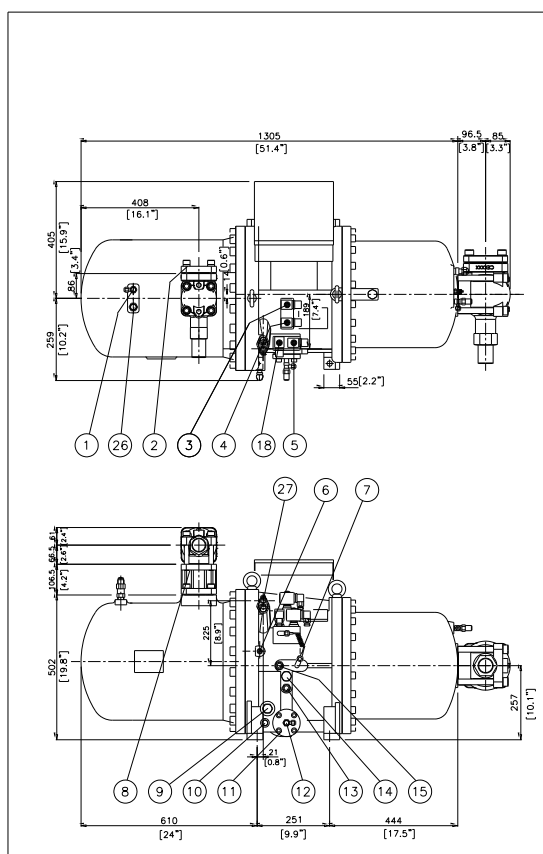

Model	RC2-310A/B
Name	Compressor outline
	No. 06

UNIT
SI: mm Imperial: [in]

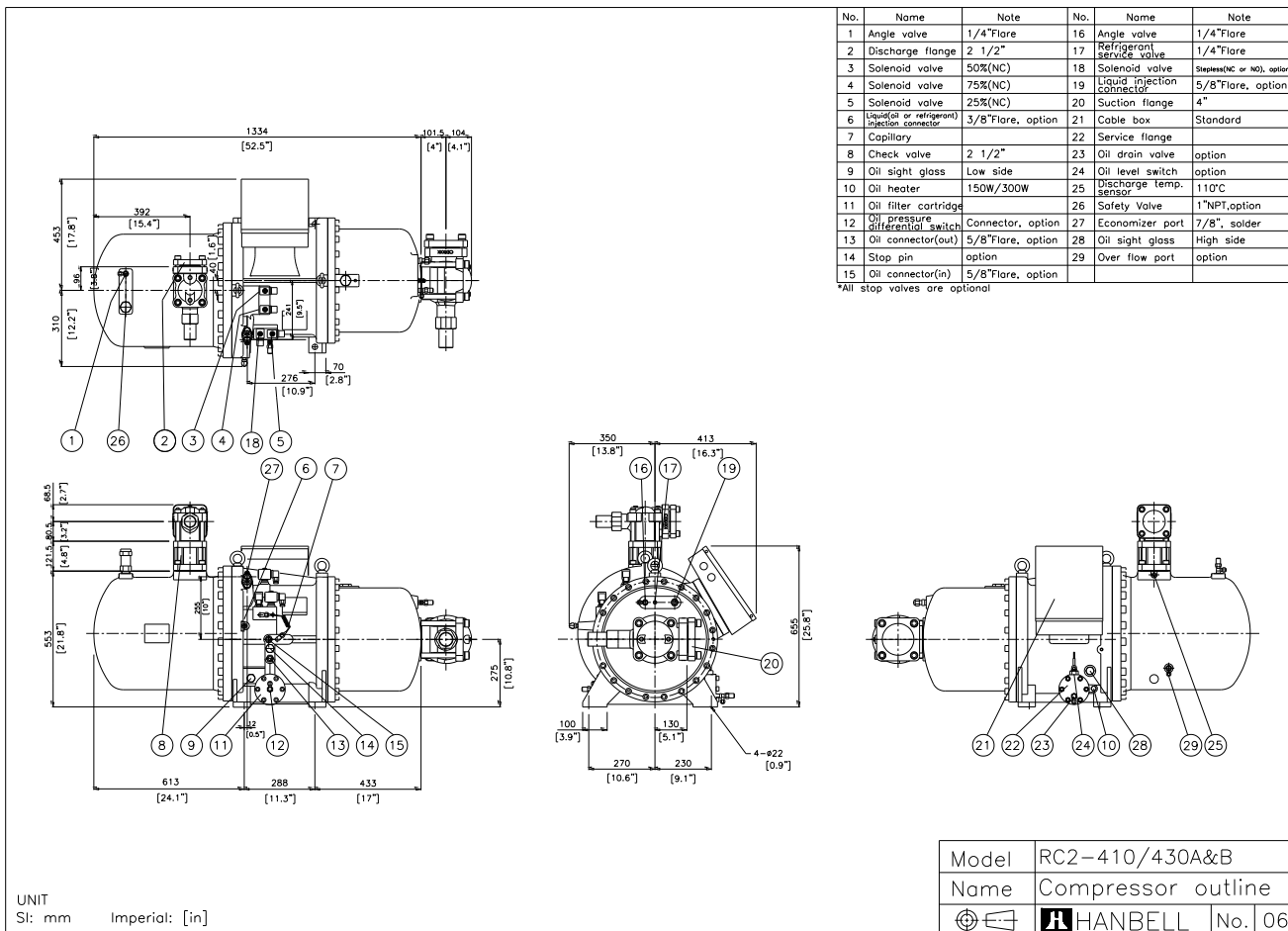
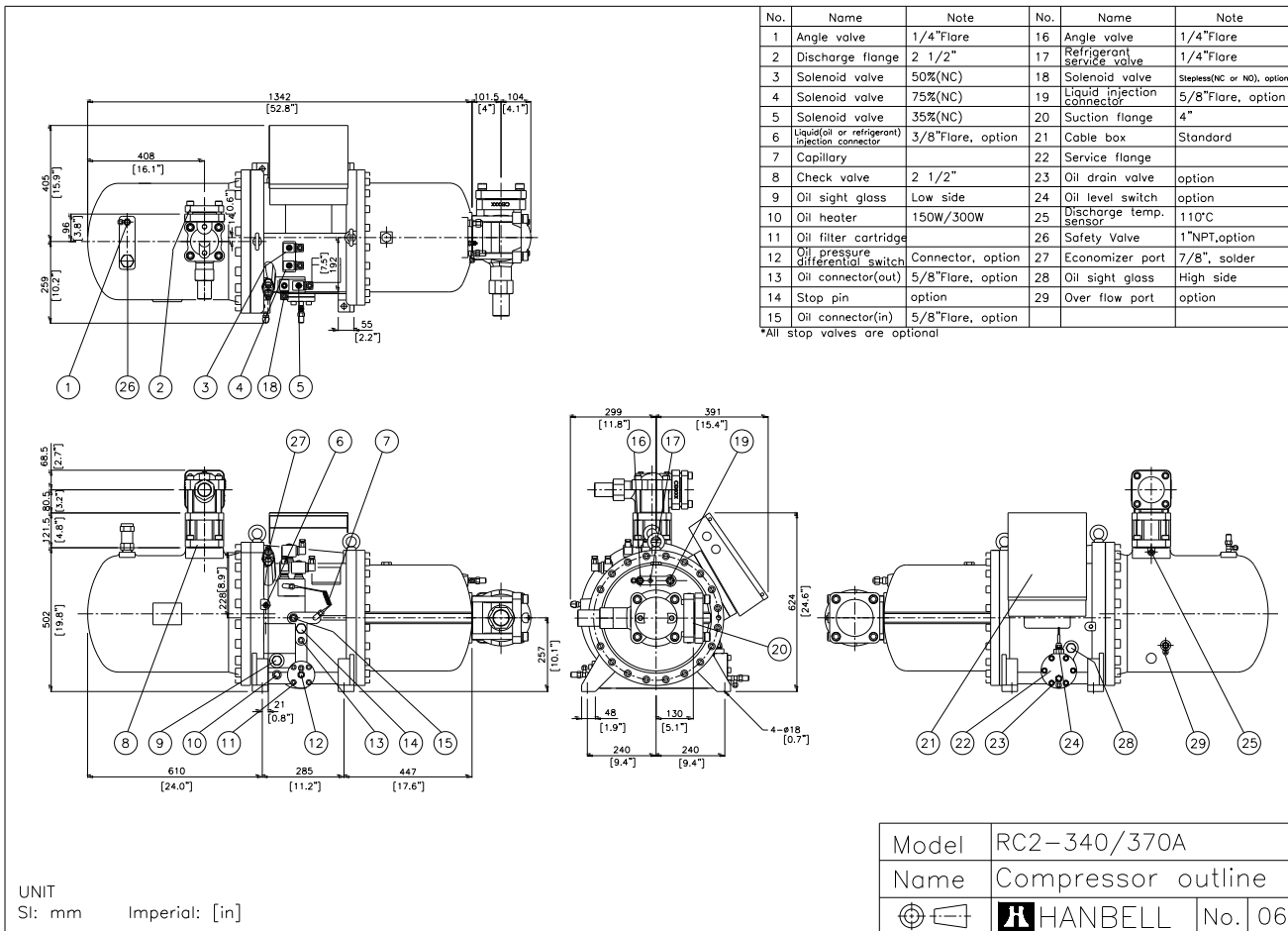

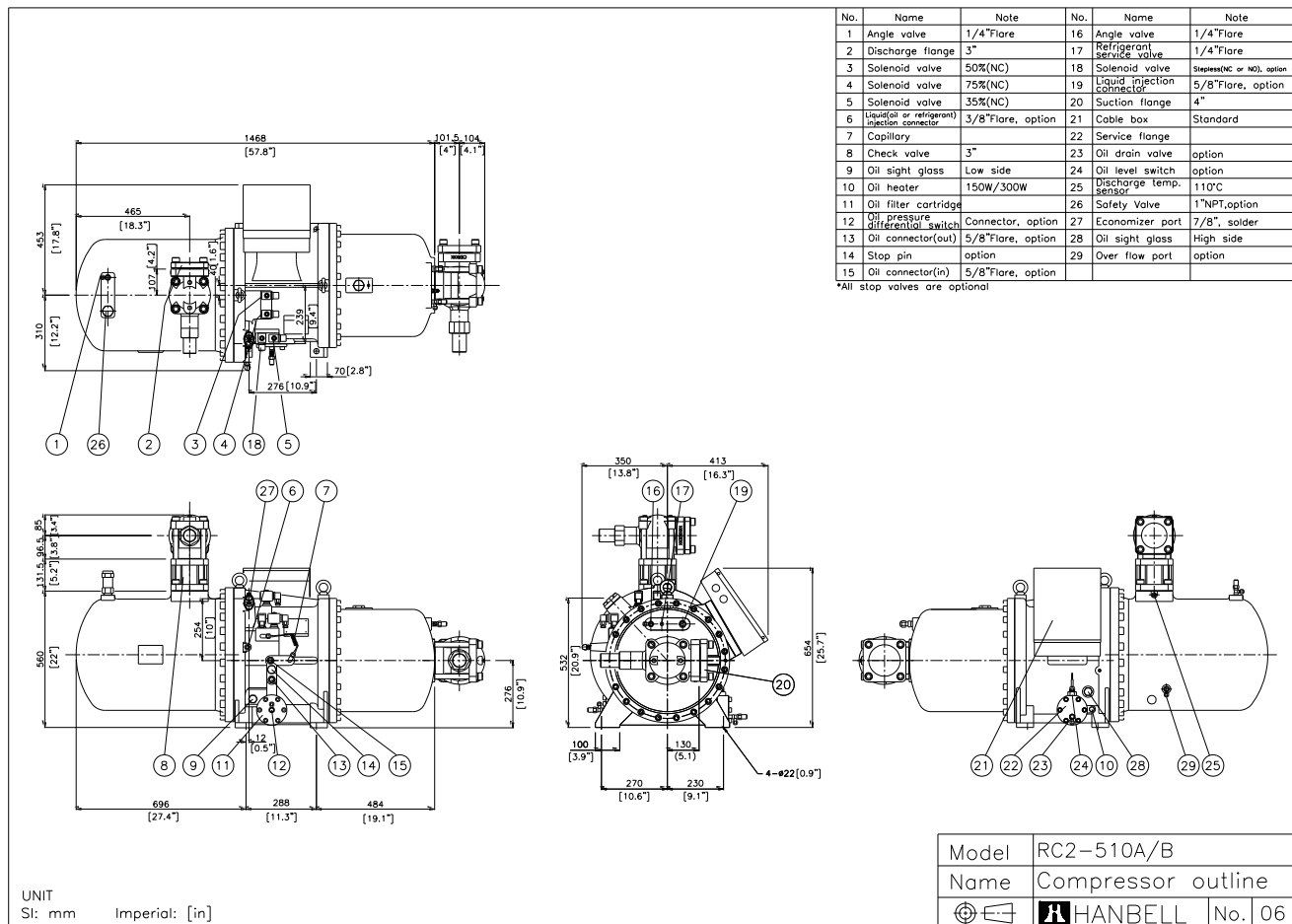
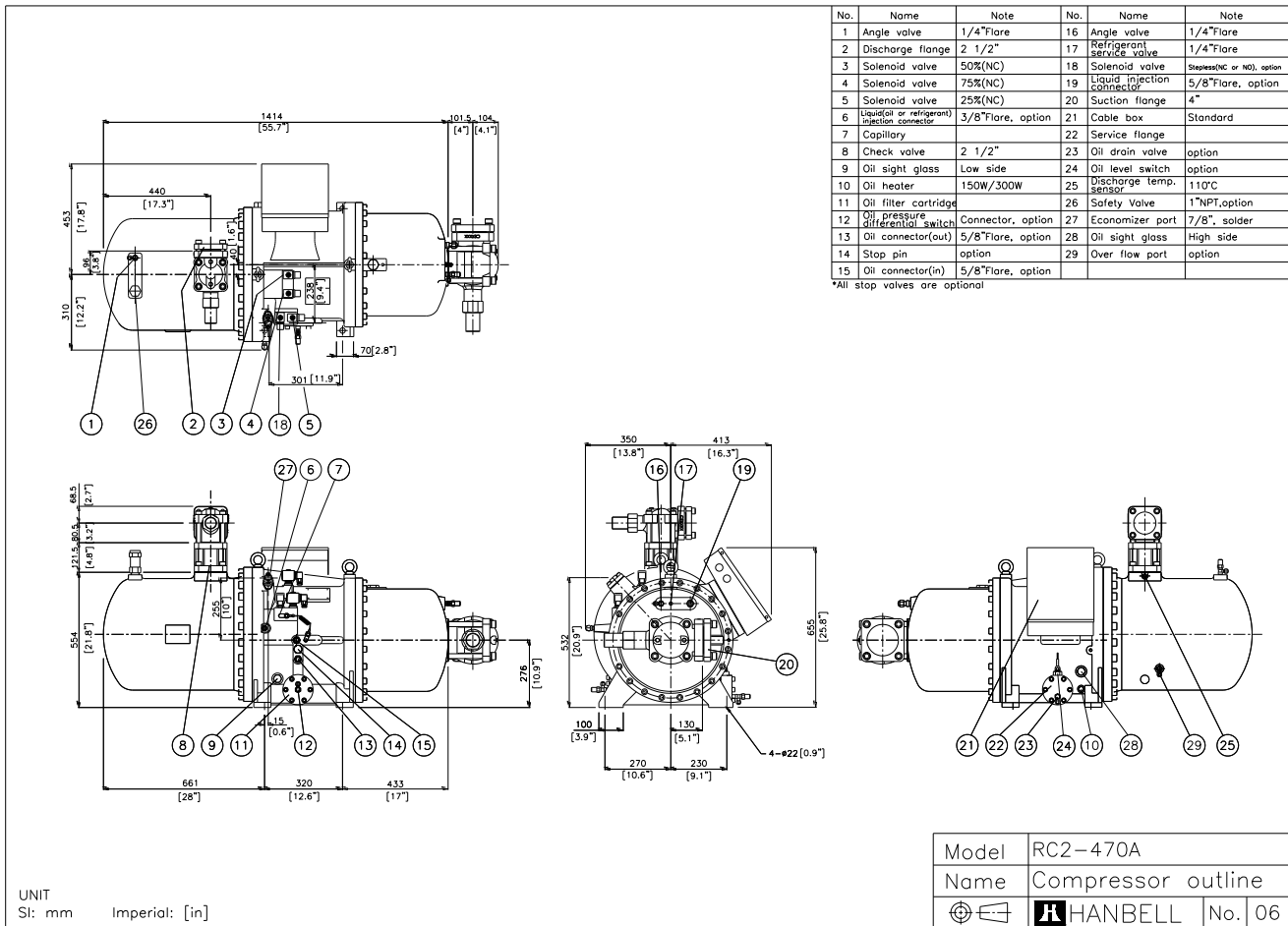

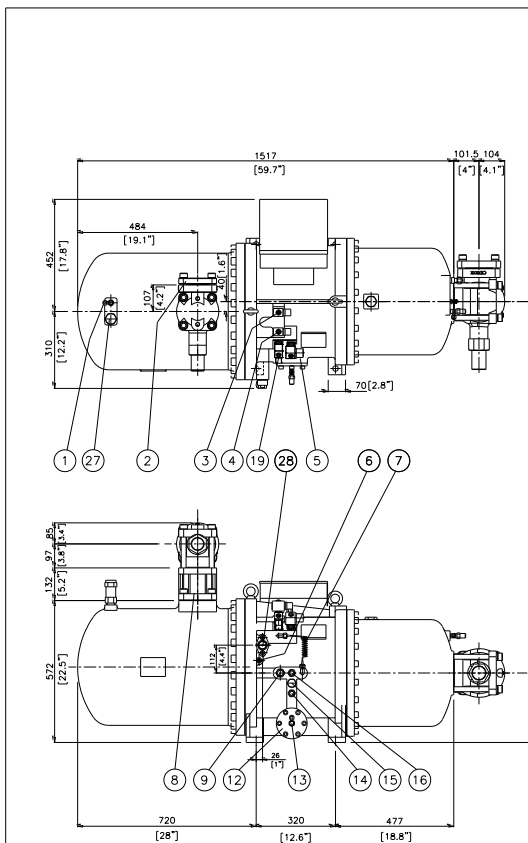

No.	Name	Note	No.	Name	Note
1	Angle valve	1/4"Flare	16	Oil connector(in)	5/8"Flare, option
2	Discharge flange	3"	17	Angle valve	1/4"Flare
3	Solenoid valve	50%(NC)	18	Refrigerant service valve	1/4"Flare
4	Solenoid valve	75%(NC)	19	Solenoid valve	Stepless(NC or NO), option
5	Solenoid valve	25%(NC)	20	Liquid injection connector	5/8"Flare, option
6	Liquid(oil or refrigerant) injection connector	3/8"Flare, option	21	Suction flange	4"
7	Capillary		22	Cable box	Standard
8	Check valve	3"	23	Service flange	
9	Oil flow sight glass		24	Oil drain valve	option
10	Oil level sight glass		25	Oil level switch	option
11	Oil heater	150W/300W	26	Discharge temp. sensor	110°C
12	Oil filter cartridge		27	Safety Valve	1"NPT,option
13	Oil pressure differential switch	option	28	Economizer connector	1 1/8",solder
14	Oil connector(out)	5/8"Flare, option	29	Over flow port	option
15	Stop pin	option			

*All stop valves are optional.

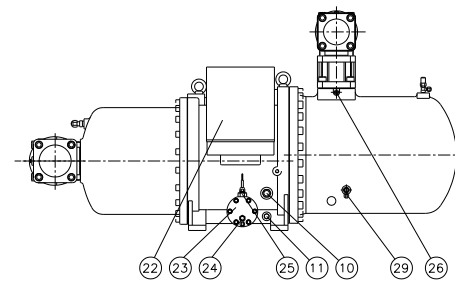
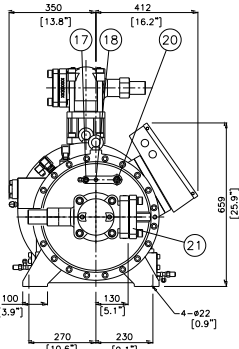

Model	RC2-550A
Name	Compressor outline
	No. 06

UNIT
SI: mm Imperial: [in]

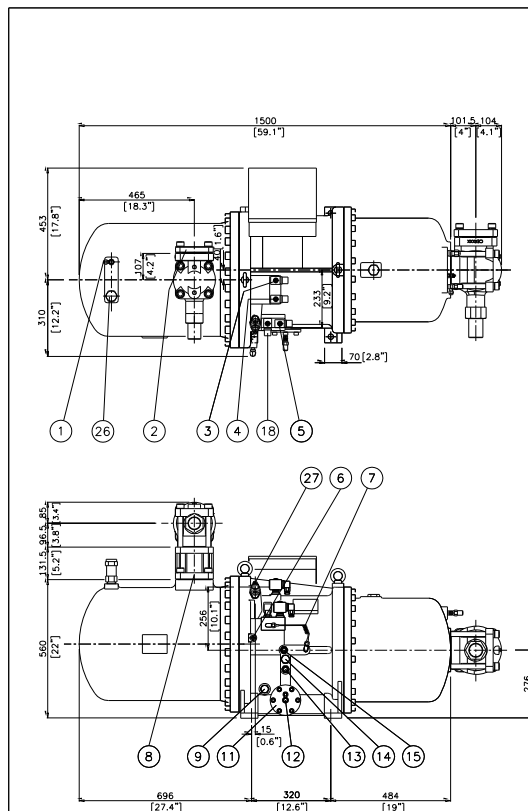

No.	Name	Note	No.	Name	Note
1	Angle valve	1/4"Flare	16	Angle valve	1/4"Flare
2	Discharge flange	3"	17	Refrigerant service valve	1/4"Flare
3	Solenoid valve	50%(NC)	18	Solenoid valve	Stepless(NC or NO), option
4	Solenoid valve	75%(NC)	19	Liquid injection connector	5/8"Flare, option
5	Solenoid valve	35%(NC)	20	Suction flange	4"
6	Liquid(oil or refrigerant) injection connector	3/8"Flare, option	21	Cable box	Standard
7	Capillary		22	Service flange	
8	Check valve	3"	23	Oil drain valve	option
9	Oil sight glass	Low side	24	Oil level switch	option
10	Oil heater	150W/300W	25	Discharge temp. sensor	110°C
11	Oil filter cartridge		26	Safety Valve	1"NPT,option
12	Oil pressure differential switch	Connector, option	27	Economizer part	1 1/8", solder
13	Oil connector(out)	5/8"Flare, option	28	Oil sight glass	High side
14	Stop pin	option	29	Over flow port	option
15	Oil connector(in)	5/8"Flare, option			

*All stop valves are optional.

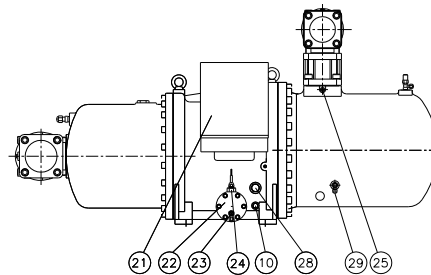
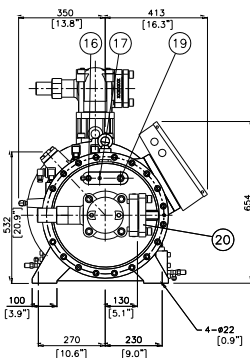

Model	RC2-580A/B
Name	Compressor outline
	No. 06

UNIT
SI: mm Imperial: [in]

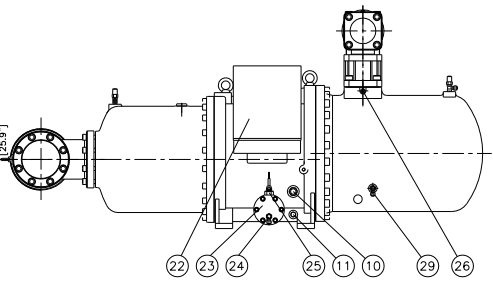
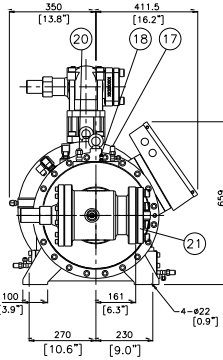
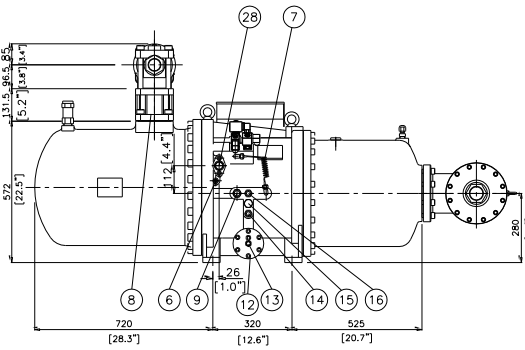
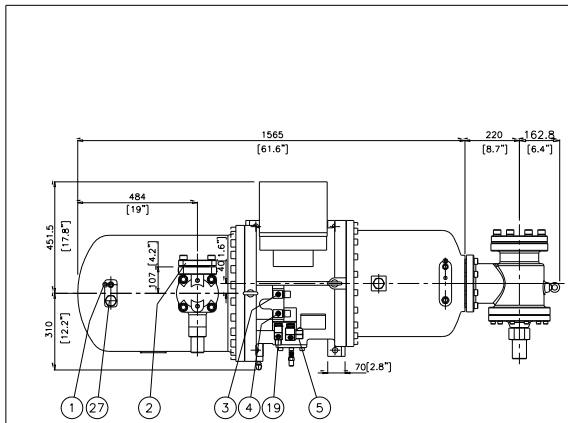

No.	Name	Note	No.	Name	Note
1	Angle valve	1/4"Flare	16	Oil connector(in)	5/8"Flare, option
2	Discharge flange	3"	17	Angle valve	1/4"Flare
3	Solenoid valve	50%(NC)	18	Refrigerant service valve	1/4"Flare
4	Solenoid valve	75%(NC)	19	Solenoid valve	Stepless(NC or NO), option
5	Solenoid valve	35%(NC)	20	Liquid injection connector	5/8"Flare, option
6	Liquid(oil or refrigerant) injection connector	3/8"Flare, option	21	Suction flange	5"
7	Capillary		22	Cable box	Standard
8	Check valve	3"	23	Service flange	
9	Oil flow sight glass		24	Oil drain valve	option
10	Oil level sight glass		25	Oil level switch	option
11	Oil heater	150W/300W	26	Discharge temp. sensor	110°C
12	Oil filter cartridge		27	Safety Valve	1"NPT,option
13	Oil pressure differential switch	Connector, option	28	Economizer connector	1 1/8", solder
14	Oil connector(out)	5/8"Flare, option	29	Over flow port	option
15	Stop pin	option			

*All stop valves are optional.

Model	RC2-620A/B
Name	Compressor outline
	HANBELL No. 06

UNIT:
SI: mm Imperial: [in]

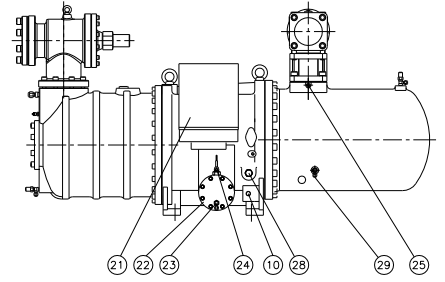
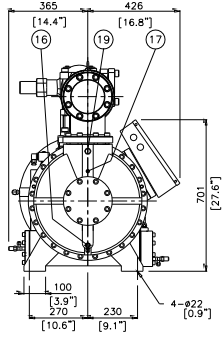
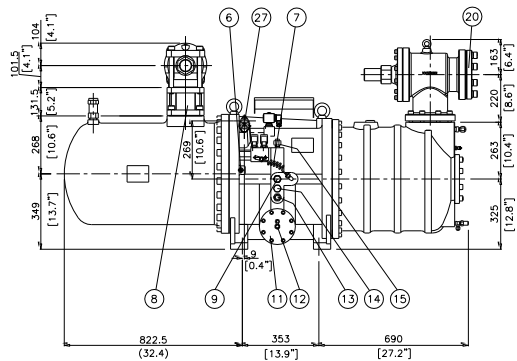
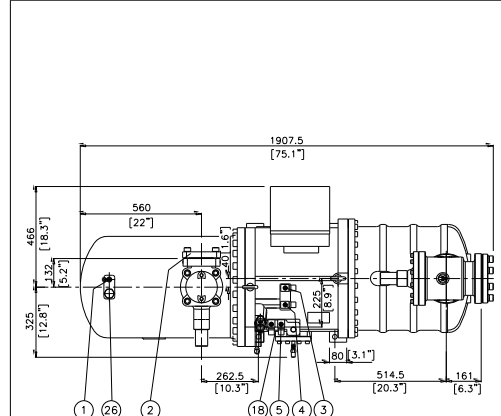

No.	Name	Note	No.	Name	Note
1	Angle valve	1/4"Flare	16	Angle valve	1/4"Flare
2	Discharge flange	4"	17	Refrigerant service valve	1/4"Flare
3	Solenoid valve	50%(NC)	18	Solenoid valve	Stepless(NC or NO), option
4	Solenoid valve	75%(NC)	19	Liquid injection connector	5/8"Flare
5	Solenoid valve	35%(NC)	20	Suction flange	5"
6	Liquid(oil or refrigerant) injection connector	3/8"Flare	21	Cable box	Standard
7	Capillary		22	Service flange	
8	Check valve	4"	23	Oil drain valve	
9	Oil flow sight glass		24	Oil level switch	
10	Oil heater	150W/300W	25	Discharge temp. sensor	110°C
11	Oil filter cartridge		26	Safety Valve	1"NPT,option
12	Oil pressure differential switch	Connector, option	27	Economizer port	1 1/8", solder
13	Oil cooler connector(out)	3/4"Flare, option	28	Oil level sight glass	
14	Stop pin	option	29	Over flow port	option
15	Oil cooler connector(in)	3/4"Flare, option			

*All stop valves are optional.

Model	RC2-710A
Name	Compressor outline
	HANBELL No. 06

UNIT:
SI: mm Imperial: [in]

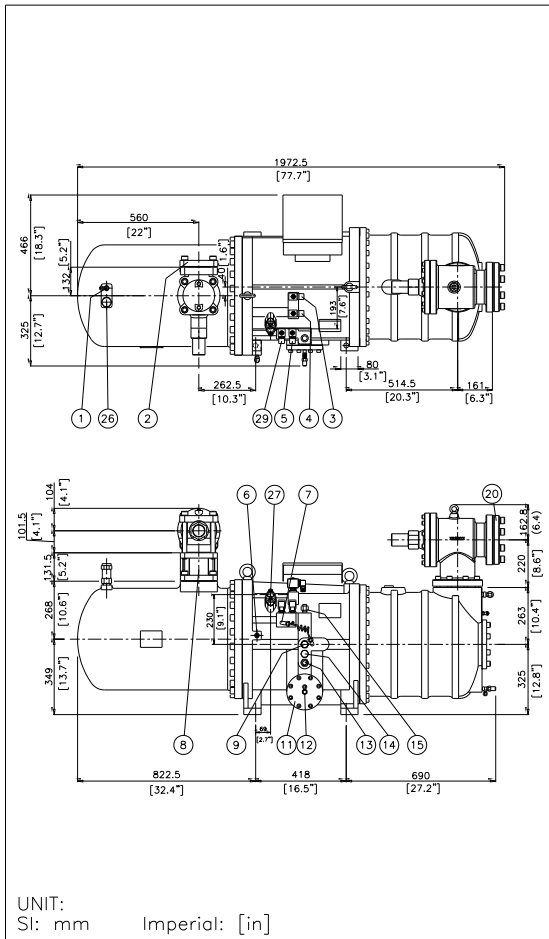

No.	Name	Note	No.	Name	Note
1	Angle valve	1/4"Flare	16	Angle valve	1/4"Flare
2	Discharge flange	4"	17	Refrigerant service valve	1/4"Flare
3	Solenoid valve	50%(NC)	18	Solenoid valve	Stepless(NC or NO), option
4	Solenoid valve	75%(NC)	19	Liquid injection connector	5/8"Flare
5	Solenoid valve	30%(NC)	20	Suction flange	5"
6	Liquid(oil or refrigerant) injection connector	3/8"Flare	21	Cable box	Standard
7	Capillary		22	Service flange	
8	Check valve	4"	23	Oil drain valve	
9	Oil flow sight glass		24	Oil level switch	
10	Oil heater	150W/300W	25	Discharge temp. sensor	110°C
11	Oil filter cartridge		26	Safety Valve	1"NPT,option
12	Oil pressure differential switch	Connector, option	27	Economizer port	1 1/8", solder
13	Oil cooler connector(out)	3/4"Flare, option	28	Oil level sight glass	
14	Stop pin	option	29	Over flow port	option
15	Oil cooler connector(in)	3/4"Flare, option			

*All stop valves are optional.

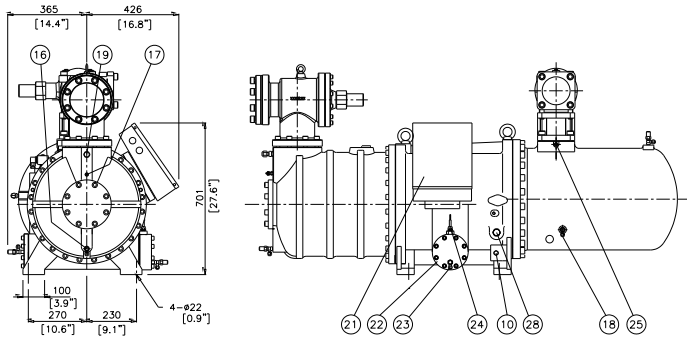

Model	RC2-790A
Name	Compressor outline
	HANBELL No. 06

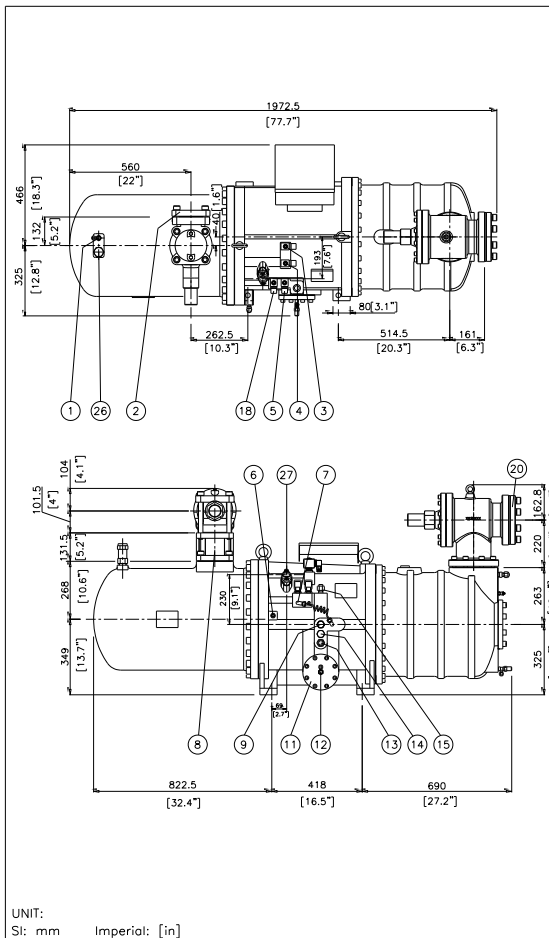

No.	Name	Note	No.	Name	Note
1	Angle valve	1/4"Flare	16	Angle valve	1/4"Flare
2	Discharge flange	4"	17	Refrigerant service valve	1/4"Flare
3	Solenoid valve	50%(NC)	18	Solenoid valve	Stepless(NC or NO), option
4	Solenoid valve	75%(NC)	19	Liquid injection connector	5/8"Flare
5	Solenoid valve	30%(NC)	20	Suction flange	5"
6	Liquid(oil or refrigerant) injection connector	3/8"Flare	21	Cable box	Standard
7	Capillary		22	Service flange	
8	Check valve	4"	23	Oil drain valve	
9	Oil flow sight glass		24	Oil level switch	
10	Oil heater	150W/300W	25	Discharge temp. sensor	110°C
11	Oil filter cartridge		26	Safety Valve	1"NPT,option
12	Oil pressure differential switch	Connector, option	27	Economizer port	1 1/8", solder
13	Oil cooler connector(out)	3/4"Flare, option	28	Oil level sight glass	
14	Stop pin	option	29	Over flow port	option
15	Oil cooler connector(in)	3/4"Flare, option			

*All stop valves are optional.

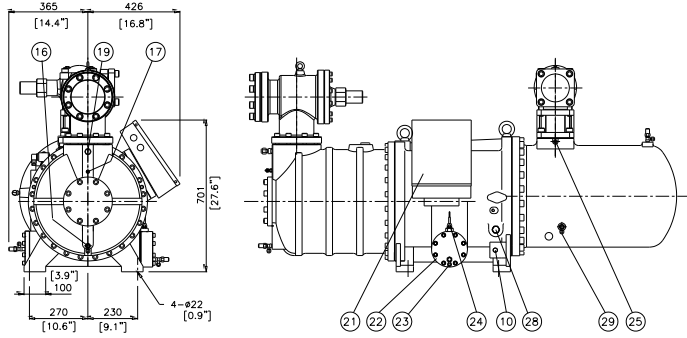

Model	RC2-830A
Name	Compressor outline
	HANBELL No. 06

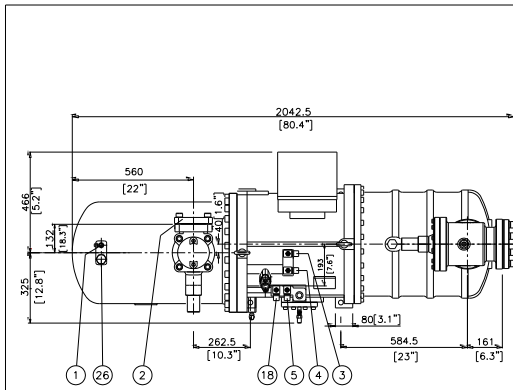

No.	Name	Note	No.	Name	Note
1	Angle valve	1/4"Flare	16	Angle valve	1/4"Flare
2	Discharge flange	4"	17	Refrigerant service valve	1/4"Flare
3	Solenoid valve	50%(NC)	18	Solenoid valve	Stepless(NC or NO), option
4	Solenoid valve	75%(NC)	19	Liquid injection connector	5/8"Flare
5	Solenoid valve	35%(NC)	20	Suction flange	5"
6	Liquid(oil or refrigerant) injection connector	3/8"Flare	21	Cable box	Standard
7	Capillary		22	Service flange	
8	Check valve	4"	23	Oil drain valve	
9	Oil flow sight glass		24	Oil level switch	
10	Oil heater	150W/300W	25	Discharge temp. sensor	110°C
11	Oil filter cartridge		26	Safety Valve	1"NPT,option
12	Oil pressure differential switch	Connector, option	27	Economizer port	1 1/8", solder
13	Oil cooler connector(out)	3/4"Flare, option	28	Oil level sight glass	
14	Stop pin	option	29	Over flow port	option
15	Oil cooler connector(in)	3/4"Flare, option			

*All stop valves are optional.

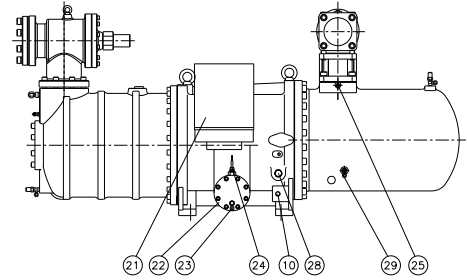
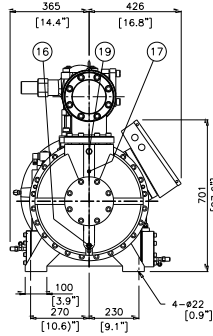
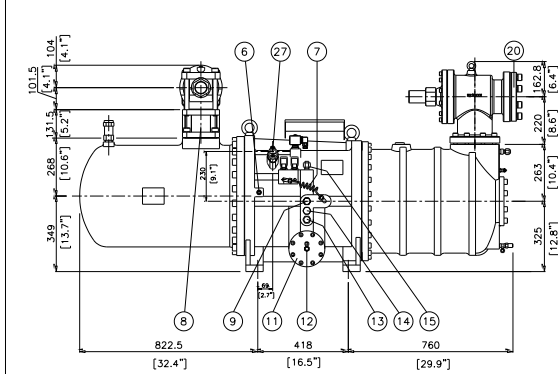

Model	RC2-930A
Name	Compressor outline
	HANBELL No. 06

UNIT:
SI: mm Imperial: [in]

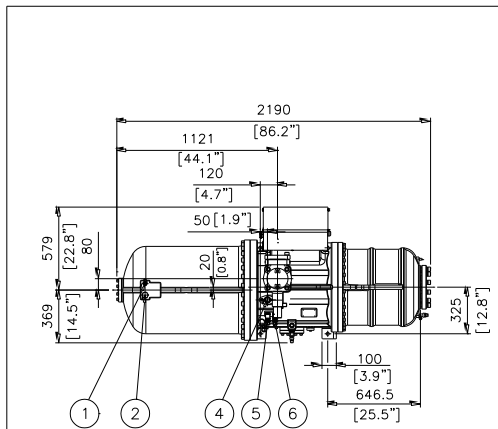

No.	Name	Note	No.	Name	Note
1	Angle valve	1/4"Flare	17	Oil cooler connector(in)	3/4"Flare
2	Safety valve	1 1/4",option	18	Oil flow sight glass	
3	Discharge flange	4"	19	Earth bolt	M8
4	Economizer port	1 3/8", solder	20	Stop Pin	option
5	Solenoid valve	Stepless(NC or NO),option	21	Oil cooler connector(out)	3/4"Flare,option
6	Solenoid valve	25%(NC)	22	Suction flange	6"
7	Solenoid valve	50%(NC)	23	Angle valve	1/4"Flare
8	Solenoid valve	75%(NC),option	24	Oil drain valve	1/4"Flare
9	Check valve	4"	25	Discharge temp. sensor	110°C
10	Displacement indicator	Option	26	Refrigerant service valve	1/4"Flare
11	Oil or Liquid refrigerant injection connector	5/8"Flare	27	Cable box	Standard
12	Oil sight glass	High side	28	service flange	
13	Oil equalization valve	1/2"Flare,option	29	Oil heater	150W/300W
14	Oil pressure differential switch	Connector, option			
15	Oil filter cartridge				
16	Oil level switch				

*All stop valve are optional

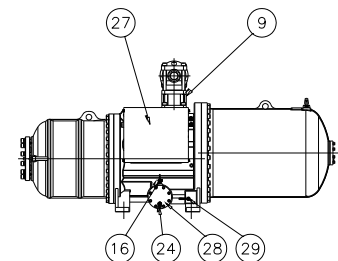
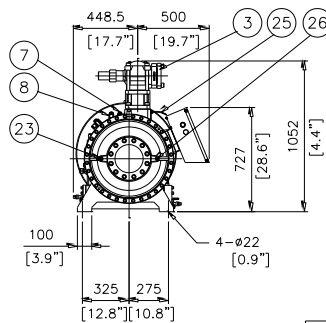
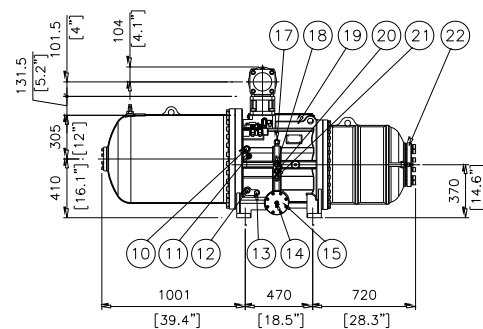

Model	RC2-1020/1130A&B
Name	Compressor outline
	HANBELL NO. 04

UNIT:
SI: mm Imperial: [in]

Date

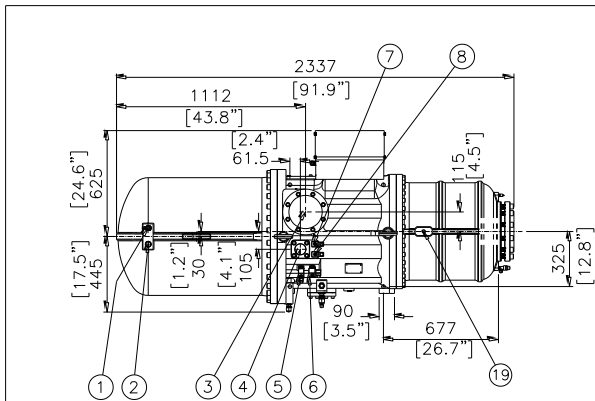

No.	Name	Note	No.	Name	Note
1	Angle valve	1/4"Flare	17	Oil cooler connector(in)	3/4"Flare
2	Safety valve	1 1/4",option	18	Oil flow sight glass	
3	Discharge flange	5"	19	Service eyebolt hole	M20
4	Economizer port	2 1/8", solder	20	Stop Pin	option
5	Solenoid valve	Stepless(NC or NO),option	21	Oil cooler connector(out)	3/4"Flare
6	Solenoid valve	25%(NC),RC2-1270 30%(NC),RC2-1530	22	Suction flange	8"
7	Solenoid valve	50%(NC)	23	Angle valve	1/4"Flare
8	Solenoid valve	75%(NC)	24	Angle valve	1/4"Flare
9	Eyebolt	M30	25	Discharge temp. sensor	110°C
10	Displacement indicator	Option	26	Refrigerant service valve	1/4"Flare
11	Oil or Liquid refrigerant injection connector		27	Cable box	Standard
12	Oil sight glass	High side	28	service flange	
13	Oil equalization valve	1/2"Flare,option	29	Oil level switch	
14	Oil filter cartridge		30	Oil drain valve	1/4"Flare
16	Oil pressure differential switch	connector,option	31	Oil heater	150W/300W

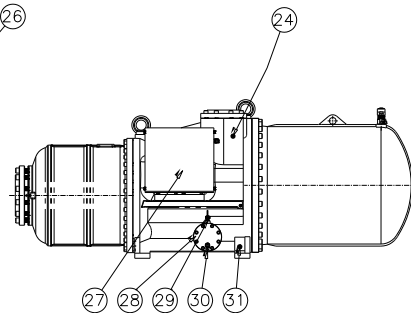
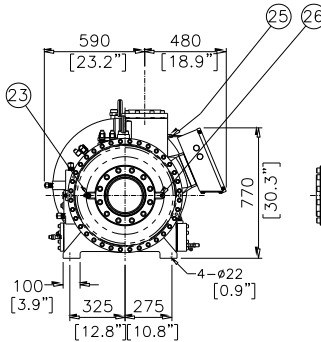
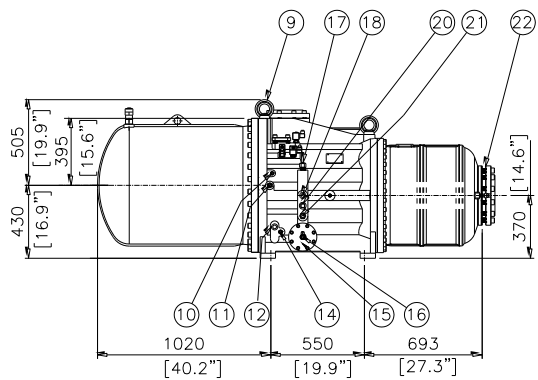

Unit:
SI:mm Imperial:[in]

Model	RC2-1270/1530A&B
Name	Compressor outline
	HANBELL NO. 04

2. RC2-B outline drawings

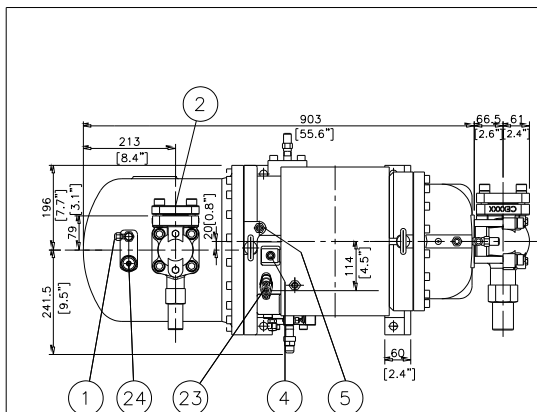

No.	Name	Note	No.	Name	Note
1	Angle valve	1/4"Flare	15	Refrigerant service valve	1/4"Flare
2	Discharge flange	1 1/2"	16	Liquid injection connector	3/8"Flare, option
3	Solenoid valve	33%(NC)	17	Suction flange	2"
4	Solenoid valve	66%(NC)	18	Cable box	Standard
5	Liquid(oil or refrigerant) injection connector	3/8"Flare, option	19	Service flange	
6	Capillary		20	Oil drain valve	option
7	Check valve	1 1/2"	21	Oil level switch	option
8	Oil sight glass		22	Discharge temp. sensor	110°C
9	Oil heater	150W/300W	23	Economizer connector	5/8",solder
10	Oil filter cartridge		24	Safety Valve	1/2"NPT, option
11	Oil pressure differential switch	option	25	Solenoid valve	Stepless(NC or NO), option
12	Oil connector(out)	3/8"Flare, option	26	Over flow port	option
13	Oil connector(in)	3/8"Flare, option	27	Oil sight glass	option
14	Angle valve	1/4"Flare			

*All stop valves are optional.

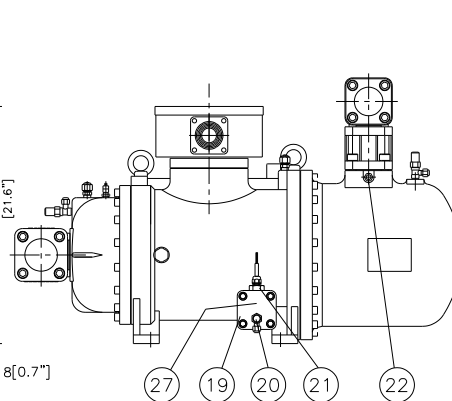
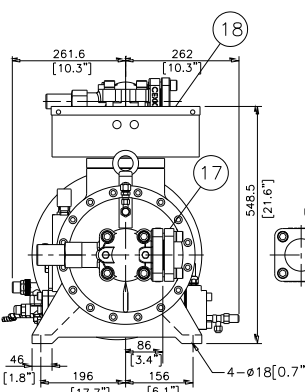
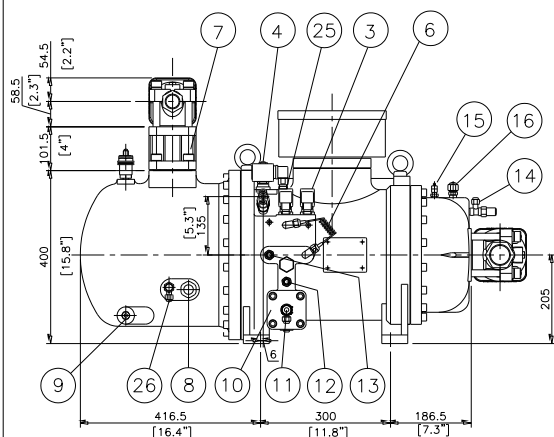

UNIT
SI: mm Imperial: [in]

Model	RC2-100/140A&B
Name	Compressor outline
	HANBELL No. 08

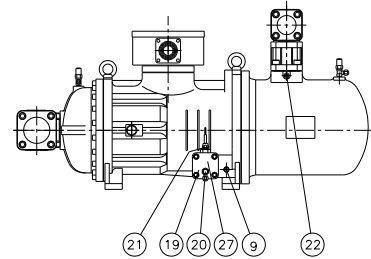
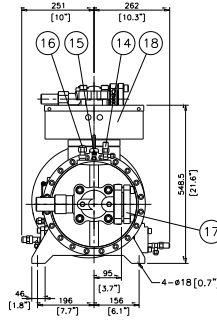
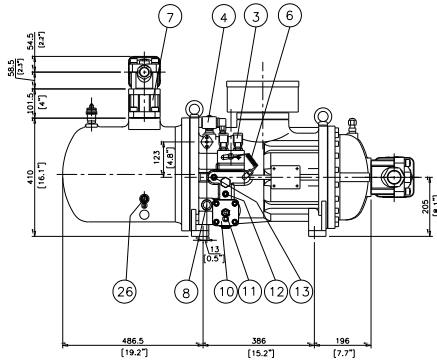
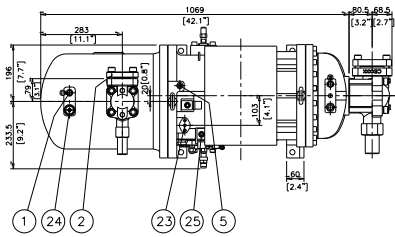

No.	Name	Note	No.	Name	Note
1	Angle valve	1/4"Flare	15	Refrigerant service valve	1/4"Flare
2	Discharge flange	1 1/2"	16	Liquid injection connector	5/8"Flare, option
3	Solenoid valve	33%(NC)	17	Suction flange	2 1/2"
4	Solenoid valve	66%(NC)	18	Cable box	Standard
5	Liquid(oil or refrigerant) injection connector	3/8"Flare, option	19	Service flange	
6	Capillary		20	Oil drain valve	option
7	Check valve	1 1/2"	21	Oil level switch	option
8	Oil sight glass		22	Discharge temp. sensor	110°C
9	Oil heater	150W/300W	23	Economizer connector	5/8",solder
10	Oil filter cartridge		24	Safety Valve	1/2"NPT, option
11	Oil pressure differential switch	option	25	Solenoid valve	Stepless(NC or NO), option
12	Oil connector(out)	3/8"Flare, option	26	Over flow port	option
13	Oil connector(in)	3/8"Flare, option	27	Oil sight glass	option
14	Angle valve	1/4"Flare			

*All stop valves are optional.

Model	RC2-180A/B
Name	Compressor outline
	HANBELL No. 08

UNIT
SI: mm Imperial: [in]

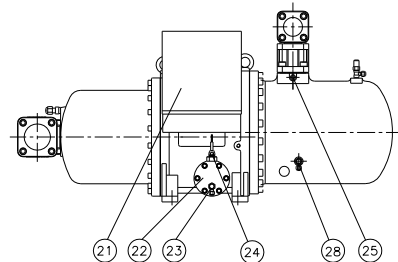
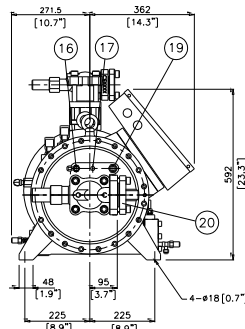
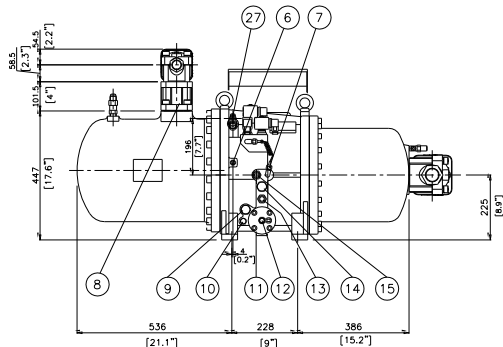
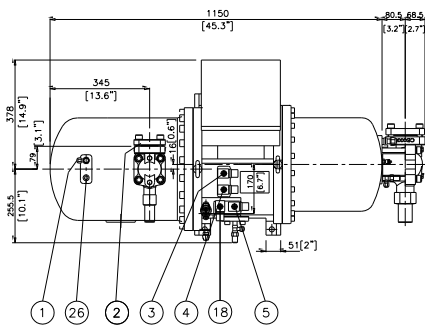

No.	Name	Note	No.	Name	Note
1	Angle valve	1/4"Flare	16	Angle valve	1/4"Flare
2	Discharge flange	1 1/2"	17	Refrigerant service valve	1/4"Flare
3	Solenoid valve	50%(NC)	18	Solenoid valve	Stepless(NC or NO),option
4	Solenoid valve	75%(NC)	19	Liquid injection connector	5/8"Flare, option
5	Solenoid valve	25%(NC)	20	Suction flange	2 1/2"
6	Liquid(oil or refrigerant) injection connector	3/8"Flare, option	21	Cable box	Standard
7	Capillary		22	Service flange	
8	Check valve	1 1/2"	23	Oil drain valve	option
9	Oil sight glass	Low side	24	Oil level switch	option
10	Oil heater	150W/300W	25	Discharge temp. sensor	110°C
11	Oil filter cartridge		26	Safety Valve	1/2"NPT,option
12	Oil pressure differential switch	Connector, option	27	Economizer port	5/8", solder
13	Oil connector(out)	5/8"Flare, option	28	Over flow port	option
14	Stop pin	option			
15	Oil connector(in)	5/8"Flare, option			

*All stop valves are optional

Model	RC2-200B
Name	Compressor outline
	HANBELL No. 06

UNIT
SI: mm Imperial: [in]

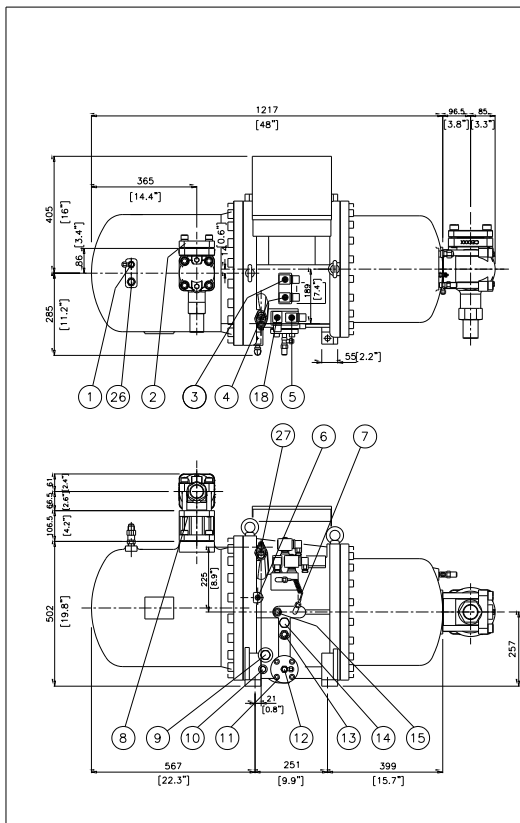

No.	Name	Note	No.	Name	Note
1	Angle valve	1/4"Flare	16	Angle valve	1/4"Flare
2	Discharge flange	2"	17	Refrigerant service valve	1/4"Flare
3	Solenoid valve	50%(NC)	18	Solenoid valve	Stepless(NC or NO), option
4	Solenoid valve	75%(NC)	19	Liquid injection connector	5/8"Flare, option
5	Solenoid valve	35%(NC)	20	Suction flange	3"
6	Liquid(oil or refrigerant) injection connector	3/8"Flare, option	21	Cable box	Standard
7	Capillary		22	Service flange	
8	Check valve	2"	23	Oil drain valve	option
9	Oil sight glass	Low side	24	Oil level switch	option
10	Oil heater	150W/300W	25	Discharge temp. sensor	110°C
11	Oil filter cartridge		26	Safety Valve	1/2"NPT,option
12	Oil pressure differential switch	Connector, option	27	Economizer port	5/8", solder
13	Oil connector(out)	5/8"Flare, option	28	Oil sight glass	High side
14	Stop pin	option	29	Over flow port	option
15	Oil connector(in)	5/8"Flare, option			

*All stop valves are optional

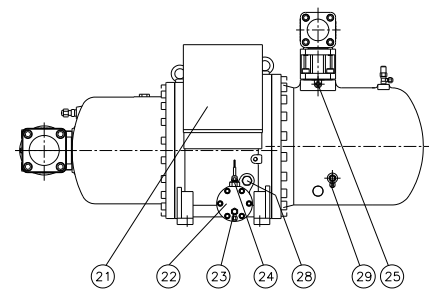
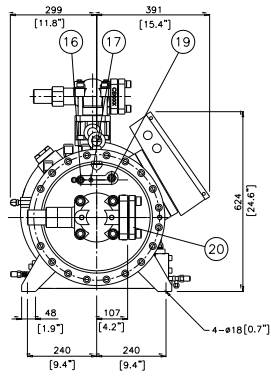

UNIT
SI: mm Imperial: [in]

Model	RC2-230A/B
Name	Compressor outline
	HANBELL No. 06

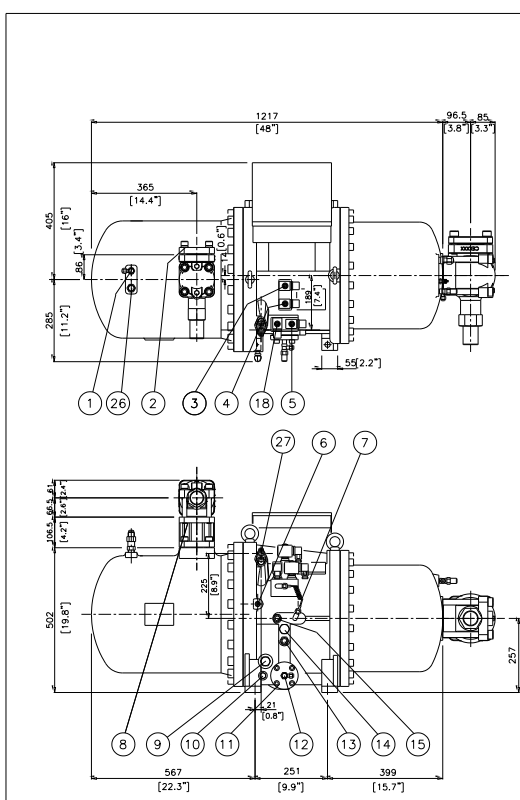

No.	Name	Note	No.	Name	Note
1	Angle valve	1/4"Flare	16	Angle valve	1/4"Flare
2	Discharge flange	2"	17	Refrigerant service valve	1/4"Flare
3	Solenoid valve	50%(NC)	18	Solenoid valve	Stepless(NC or NO), option
4	Solenoid valve	75%(NC)	19	Liquid injection connector	5/8"Flare, option
5	Solenoid valve	25%(NC)	20	Suction flange	3"
6	Liquid(oil or refrigerant) injection connector	3/8"Flare, option	21	Cable box	Standard
7	Capillary		22	Service flange	
8	Check valve	2"	23	Oil drain valve	option
9	Oil sight glass	Low side	24	Oil level switch	option
10	Oil heater	150W/300W	25	Discharge temp. sensor	110°C
11	Oil filter cartridge		26	Safety Valve	1/2"NPT,option
12	Oil pressure differential switch	Connector, option	27	Economizer port	5/8", solder
13	Oil connector(out)	5/8"Flare, option	28	Oil sight glass	High side
14	Stop pin	option	29	Over flow port	option
15	Oil connector(in)	5/8"Flare, option			

*All stop valves are optional

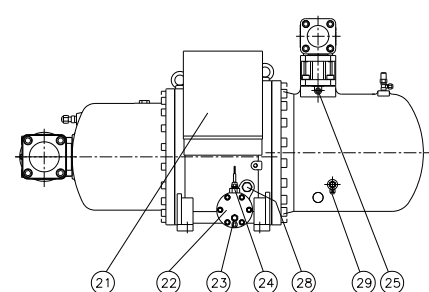
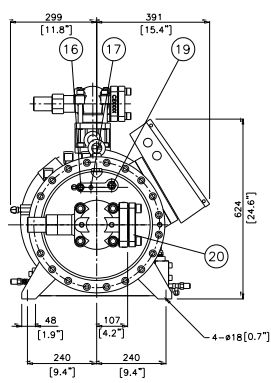

UNIT
SI: mm Imperial: [in]

Model	RC2-260A/B
Name	Compressor outline
	HANBELL No. 06

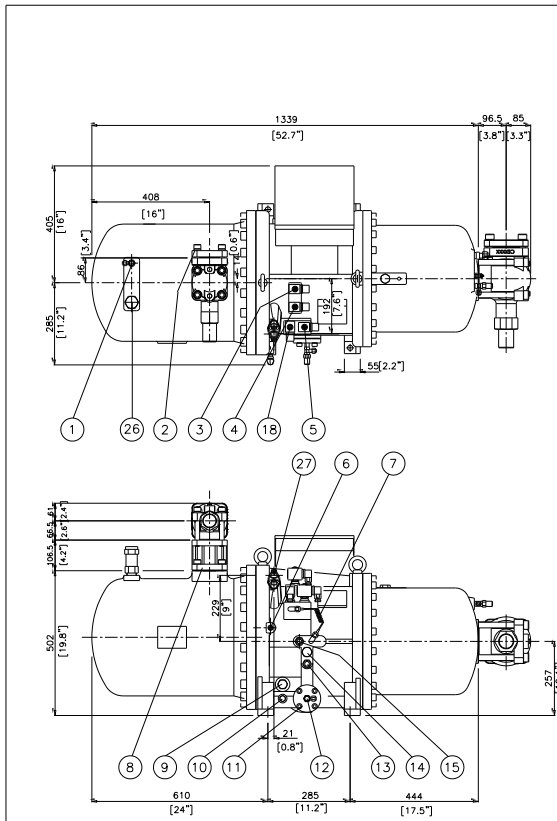

No.	Name	Note	No.	Name	Note
1	Angle valve	1/4"Flare	16	Angle valve	1/4"Flare
2	Discharge flange	2"	17	Refrigerant service valve	1/4"Flare
3	Solenoid valve	50%(NC)	18	Solenoid valve	Stepless(NC or NO), option
4	Solenoid valve	75%(NC)	19	Liquid injection connector	5/8"Flare, option
5	Solenoid valve	25%(NC)	20	Suction flange	3"
6	Liquid(oil or refrigerant) injection connector	3/8"Flare, option	21	Cable box	Standard
7	Capillary		22	Service flange	
8	Check valve	2"	23	Oil drain valve	option
9	Oil sight glass	Low side	24	Oil level switch	option
10	Oil heater	150W/300W	25	Discharge temp. sensor	110°C
11	Oil filter cartridge		26	Safety Valve	1"NPT,option
12	Oil pressure differential switch	Connector, option	27	Economizer part	7/8", solder
13	Oil connector(out)	5/8"Flare, option	28	Oil sight glass	High side
14	Stop pin	option	29	Over flow port	option
15	Oil connector(in)	5/8"Flare, option			

*All stop valves are optional

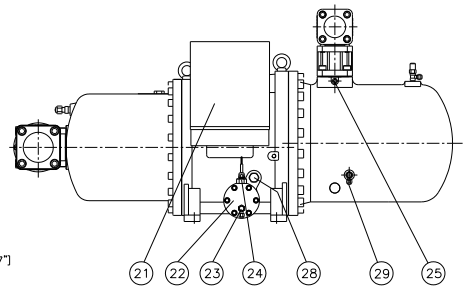
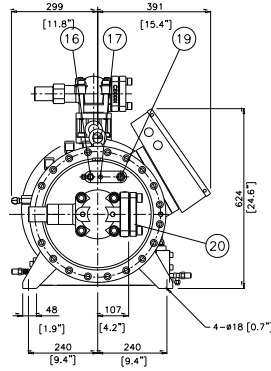

UNIT
SI: mm Imperial: [in]

Model	RC2-300/320B
Name	Compressor outline
	HANBELL No. 06

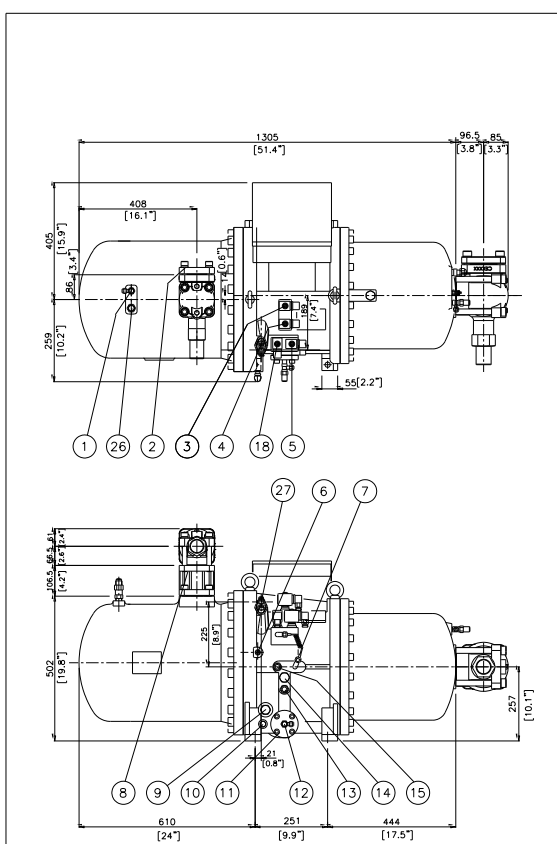

No.	Name	Note	No.	Name	Note
1	Angle valve	1/4"Flare	16	Angle valve	1/4"Flare
2	Discharge flange	2"	17	Refrigerant service valve	1/4"Flare
3	Solenoid valve	50%(NC)	18	Solenoid valve	Stepless(NC or NO), option
4	Solenoid valve	75%(NC)	19	Liquid injection connector	5/8"Flare, option
5	Solenoid valve	35%(NC)	20	Suction flange	3"
6	Liquid(oil or refrigerant) injection connector	3/8"Flare, option	21	Cable box	Standard
7	Capillary		22	Service flange	
8	Check valve	2"	23	Oil drain valve	option
9	Oil sight glass	Low side	24	Oil level switch	option
10	Oil heater	150W/300W	25	Discharge temp. sensor	110°C
11	Oil filter cartridge		26	Safety Valve	1"NPT,option
12	Oil pressure differential switch	Connector, option	27	Economizer part	7/8", solder
13	Oil connector(out)	5/8"Flare, option	28	Oil sight glass	High side
14	Stop pin	option	29	Over flow port	option
15	Oil connector(in)	5/8"Flare, option			

*All stop valves are optional

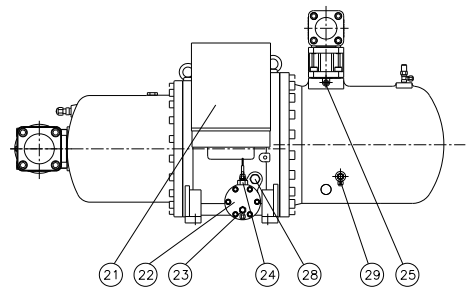
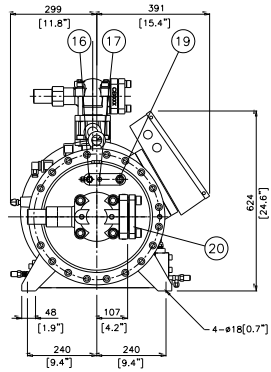

UNIT
SI: mm Imperial: [in]

Model	RC2-310A/B
Name	Compressor outline
	HANBELL No. 06

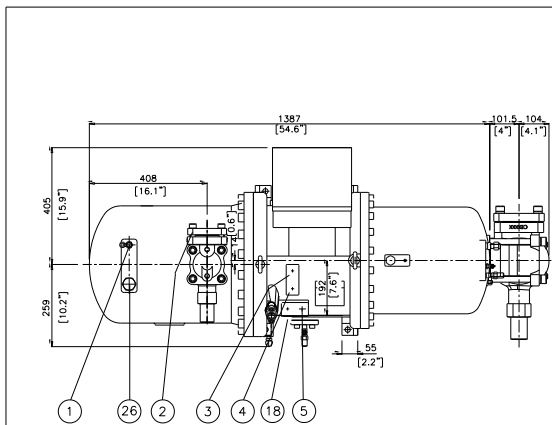

No.	Name	Note	No.	Name	Note
1	Angle valve	1/4"Flare	16	Angle valve	1/4"Flare
2	Discharge flange	2 1/2"	17	Refrigerant service valve	1/4"Flare
3	Solenoid valve	50%(NC)	18	Solenoid valve	Stepless(NC or NO), option
4	Solenoid valve	75%(NC)	19	Liquid injection connector	5/8"Flare, option
5	Solenoid valve	35%(NC)	20	Suction flange	4"
6	Liquid(oil or refrigerant) injection connector	3/8"Flare, option	21	Cable box	Standard
7	Capillary		22	Service flange	
8	Check valve	2 1/2"	23	Oil drain valve	option
9	Oil sight glass	Low side	24	Oil level switch	option
10	Oil heater	150W/300W	25	Discharge temp. sensor	110°C
11	Oil filter cartridge		26	Safety Valve	1"NPT,option
12	Oil pressure differential switch	Connector, option	27	Economizer part	7/8", solder
13	Oil connector(out)	5/8"Flare, option	28	Oil sight glass	High side
14	Stop pin	option	29	Over flow port	option
15	Oil connector(in)	5/8"Flare, option			

*All stop valves are optional

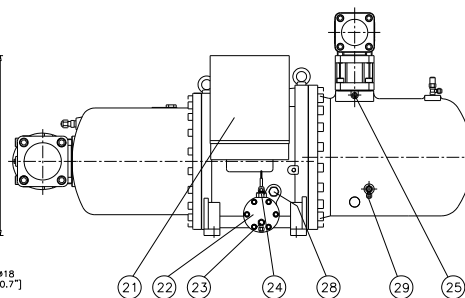
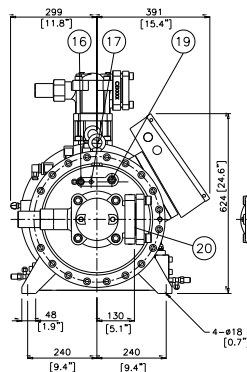
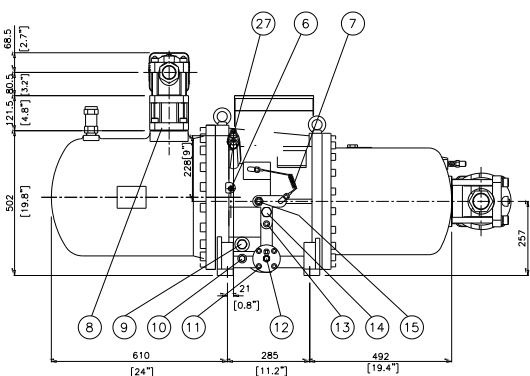

UNIT
SI: mm Imperial: [in]

Model	RC2-340/370B
Name	Compressor outline
	No. 06

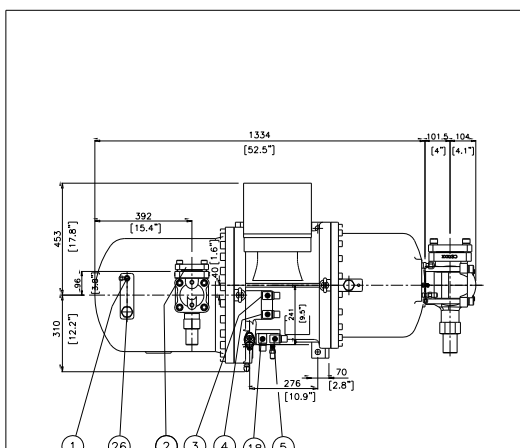

No.	Name	Note	No.	Name	Note
1	Angle valve	1/4"Flare	16	Angle valve	1/4"Flare
2	Discharge flange	2 1/2"	17	Refrigerant service valve	1/4"Flare
3	Solenoid valve	50%(NC)	18	Solenoid valve	Stepless(NC or NO), option
4	Solenoid valve	75%(NC)	19	Liquid injection connector	5/8"Flare, option
5	Solenoid valve	25%(NC)	20	Suction flange	4"
6	Liquid(oil or refrigerant) injection connector	3/8"Flare, option	21	Cable box	Standard
7	Capillary		22	Service flange	
8	Check valve	2 1/2"	23	Oil drain valve	option
9	Oil sight glass	Low side	24	Oil level switch	option
10	Oil heater	150W/300W	25	Discharge temp. sensor	110°C
11	Oil filter cartridge		26	Safety Valve	1"NPT,option
12	Oil pressure differential switch	Connector, option	27	Economizer port	7/8", solder
13	Oil connector(out)	5/8"Flare, option	28	Oil sight glass	High side
14	Stop pin	option	29	Over flow port	option
15	Oil connector(in)	5/8"Flare, option			

*All stop valves are optional

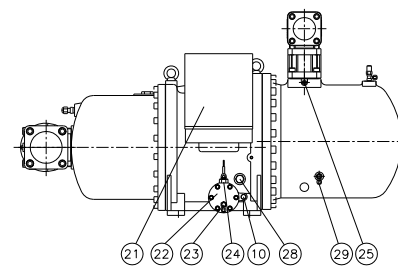
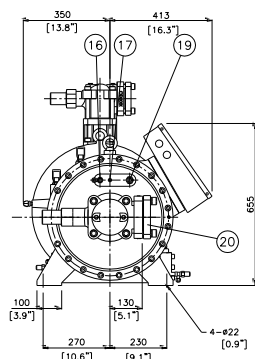
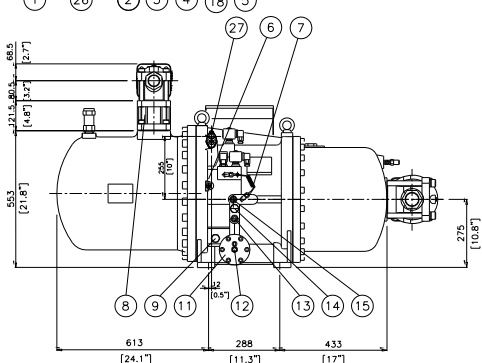

UNIT
SI: mm Imperial: [in]

Model	RC2-410/430A&B
Name	Compressor outline
	No. 06

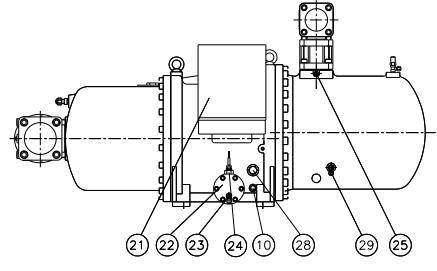
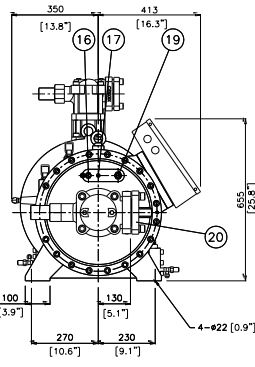
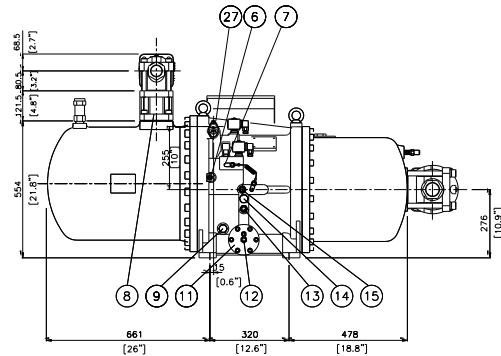
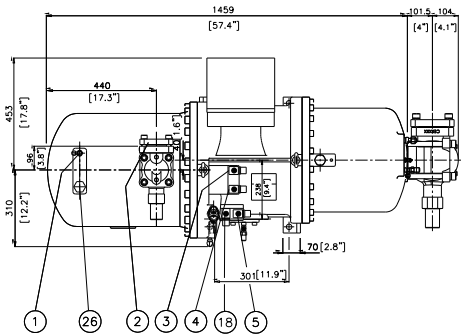

No.	Name	Note	No.	Name	Note
1	Angle valve	1/4"Flare	16	Angle valve	1/4"Flare
2	Discharge flange	2 1/2"	17	Refrigerant service valve	1/4"Flare
3	Solenoid valve	50%(NC)	18	Solenoid valve	Stepless(NC or NO), option
4	Solenoid valve	75%(NC)	19	Liquid injection solenoid	5/8"Flare, option
5	Solenoid valve	25%(NC)	20	Suction flange	4"
6	Liquid(oil or refrigerant) injection connector	3/8"Flare, option	21	Cable box	Standard
7	Capillary		22	Service flange	
8	Check valve	2 1/2"	23	Oil drain valve	option
9	Oil sight glass	Low side	24	Oil level switch	option
10	Oil heater	150W/300W	25	Discharge temp. sensor	110°C
11	Oil filter cartridge		26	Safety Valve	1"NPT,option
12	Oil pressure differential switch	Connector, option	27	Economizer port	7/8", solder
13	Oil connector(out)	5/8"Flare, option	28	Oil sight glass	High side
14	Stop pin	option	29	Over flow port	option
15	Oil connector(in)	5/8"Flare, option			

*All stop valves are optional

UNIT
SI: mm Imperial: [in]

Model	RC2-470B
Name	Compressor outline
	No. 06

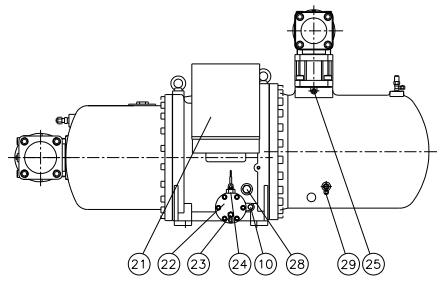
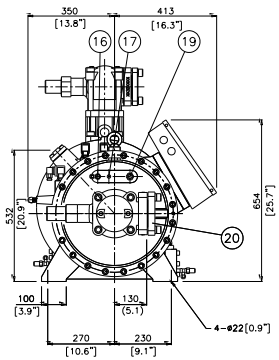
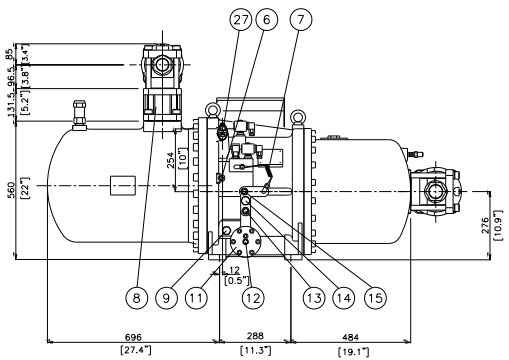
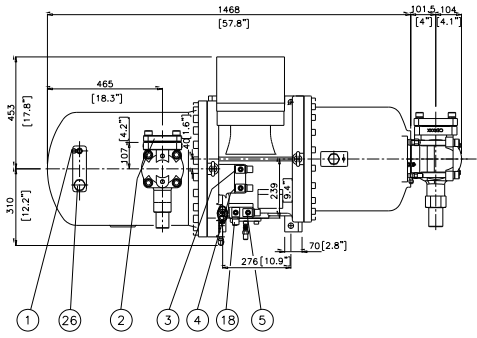

No.	Name	Note	No.	Name	Note
1	Angle valve	1/4"Flare	16	Angle valve	1/4"Flare
2	Discharge flange	3"	17	Refrigerant service valve	1/4"Flare
3	Solenoid valve	50%(NC)	18	Solenoid valve	Stepless(NC or NO), option
4	Solenoid valve	75%(NC)	19	Liquid injection solenoid	5/8"Flare, option
5	Solenoid valve	35%(NC)	20	Suction flange	4"
6	Liquid(oil or refrigerant) injection connector	3/8"Flare, option	21	Cable box	Standard
7	Capillary		22	Service flange	
8	Check valve	3"	23	Oil drain valve	option
9	Oil sight glass	Low side	24	Oil level switch	option
10	Oil heater	150W/300W	25	Discharge temp. sensor	110°C
11	Oil filter cartridge		26	Safety Valve	1"NPT,option
12	Oil pressure differential switch	Connector, option	27	Economizer port	7/8", solder
13	Oil connector(out)	5/8"Flare, option	28	Oil sight glass	High side
14	Stop pin	option	29	Over flow port	option
15	Oil connector(in)	5/8"Flare, option			

*All stop valves are optional

UNIT
SI: mm Imperial: [in]

Model	RC2-510A/B
Name	Compressor outline
	No. 06

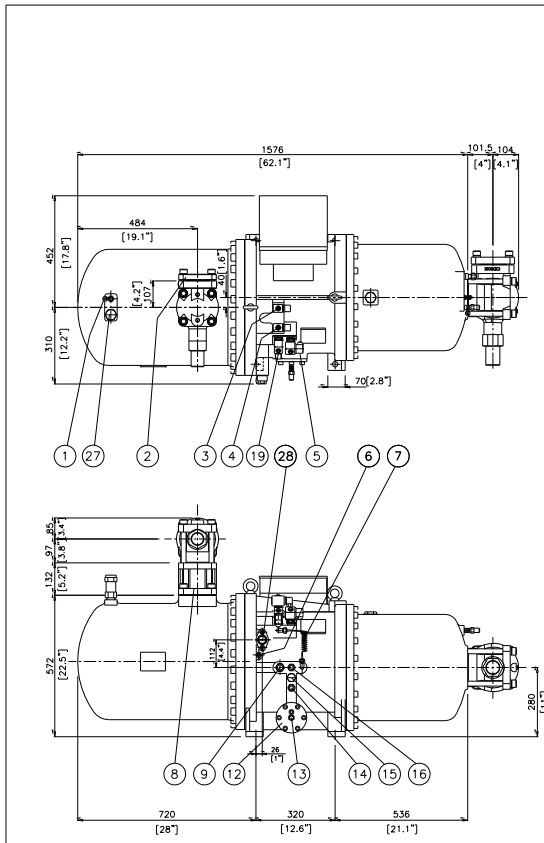

No.	Name	Note	No.	Name	Note
1	Angle valve	1/4"Flare	16	Oil connector(in)	5/8"Flare, option
2	Discharge flange	3"	17	Angle valve	1/4"Flare
3	Solenoid valve	50%(NC)	18	Refrigerant service valve	1/4"Flare
4	Solenoid valve	75%(NC)	19	Solenoid valve	Stepless(NC or NO), option
5	Solenoid valve	25%(NC)	20	Liquid injection connector	5/8"Flare, option
6	Liquid(oil or refrigerant) injection connector	3/8"Flare, option	21	Suction flange	4"
7	Capillary		22	Cable box	Standard
8	Check valve	3"	23	Service flange	
9	Oil flow sight glass		24	Oil drain valve	option
10	Oil level sight glass		25	Oil level switch	option
11	Oil heater	150W/300W	26	Discharge temp. sensor	110°C
12	Oil filter cartridge		27	Safety Valve	1"NPT,option
13	Oil pressure differential switch	option	28	Economizer connector	1 1/8",solder
14	Oil connector(out)	5/8"Flare, option	29	Over flow port	option
15	Stop pin	option			

*All stop valves are optional.

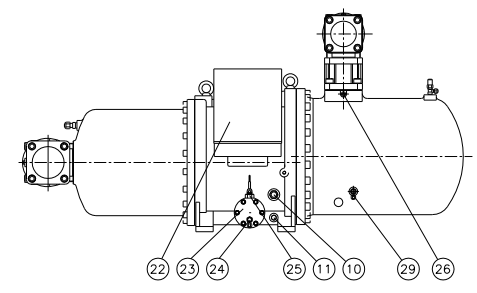
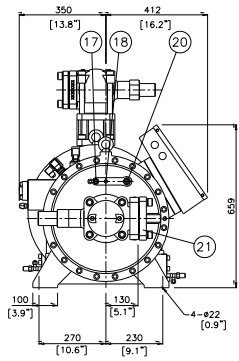

Model	RC2-550B
Name	Compressor outline
	HANBELL No. 06

UNIT:
SI: mm Imperial: [in]

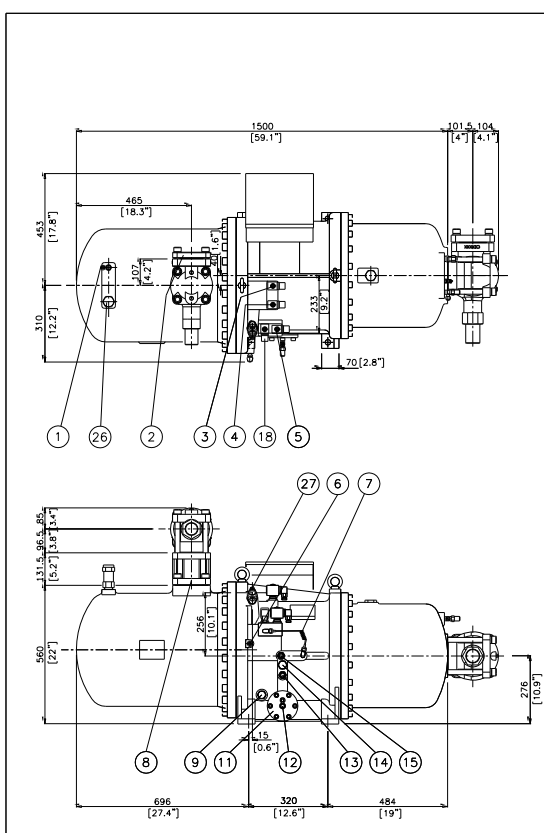

No.	Name	Note	No.	Name	Note
1	Angle valve	1/4"Flare	16	Angle valve	1/4"Flare
2	Discharge flange	3"	17	Refrigerant service valve	1/4"Flare
3	Solenoid valve	50%(NC)	18	Solenoid valve	Stepless(NC or NO), option
4	Solenoid valve	75%(NC)	19	Liquid injection connector	5/8"Flare, option
5	Solenoid valve	35%(NC)	20	Suction flange	4"
6	Liquid(oil or refrigerant) injection connector	3/8"Flare, option	21	Cable box	Standard
7	Capillary		22	Service flange	
8	Check valve	3"	23	Oil drain valve	option
9	Oil sight glass	Low side	24	Oil level switch	option
10	Oil heater	150W/300W	25	Discharge temp. sensor	110°C
11	Oil filter cartridge		26	Safety Valve	1"NPT,option
12	Oil pressure differential switch	Connector, option	27	Economizer port	1 1/8", solder
13	Oil connector(out)	5/8"Flare, option	28	Oil sight glass	High side
14	Stop pin	option	29	Over flow port	option
15	Oil connector(in)	5/8"Flare, option			

*All stop valves are optional

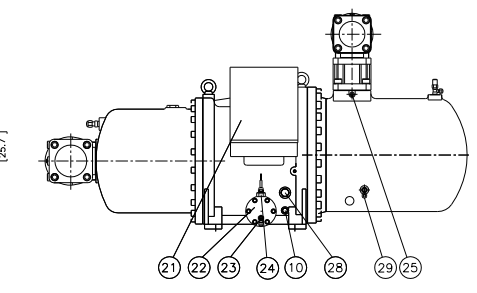
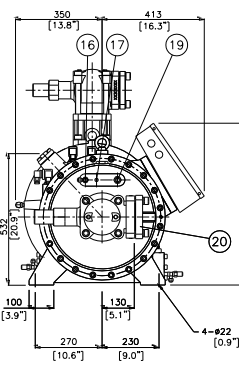

Model	RC2-580A/B
Name	Compressor outline
	HANBELL No. 06

UNIT:
SI: mm Imperial: [in]

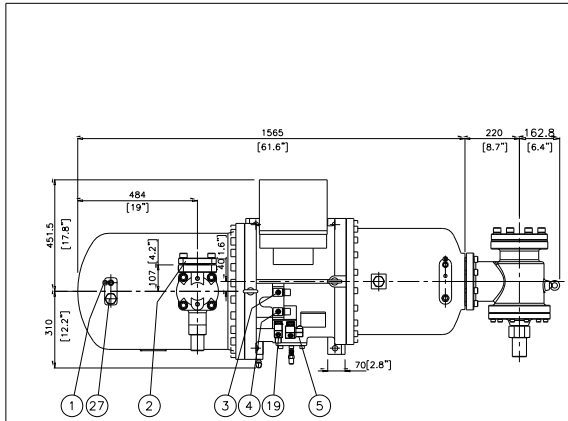

No.	Name	Note	No.	Name	Note
1	Angle valve	1/4"Flare	16	Oil connector(in)	5/8"Flare, option
2	Discharge flange	3"	17	Angle valve	1/4"Flare
3	Solenoid valve	50%(NC)	18	Refrigerant service valve	1/4"Flare
4	Solenoid valve	75%(NC)	19	Solenoid valve	Stepless(NC or NO), option
5	Solenoid valve	35%(NC)	20	Liquid injection connector	5/8"Flare, option
6	Liquid(oil or refrigerant) injection connector	3/8"Flare, option	21	Suction flange	5"
7	Capillary		22	Cable box	Standard
8	Check valve	3"	23	Service flange	
9	Oil flow sight glass		24	Oil drain valve	option
10	Oil level sight glass		25	Oil level switch	option
11	Oil heater	150W/300W	26	Discharge temp. sensor	110°C
12	Oil filter cartridge		27	Safety Valve	1"NPT,option
13	Oil pressure differential switch	Connector, option	28	Economizer connector	1 1/8", solder
14	Oil connector(out)	5/8"Flare, option	29	Over flow port	option
15	Stop pin	option			

*All stop valves are optional.

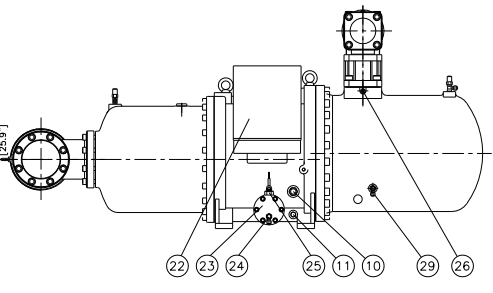
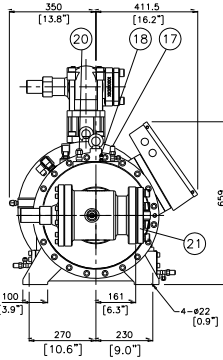
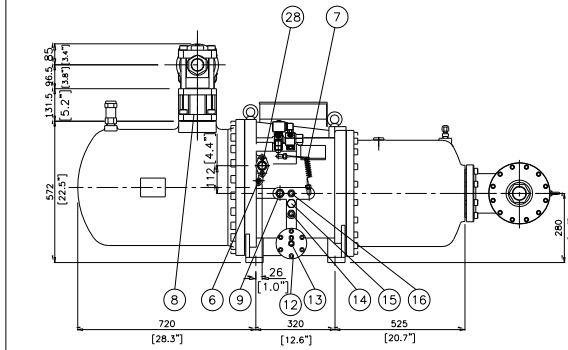

Model	RC2-620A/B
Name	Compressor outline
	HANBELL No. 06

UNIT:
SI: mm Imperial: [in]

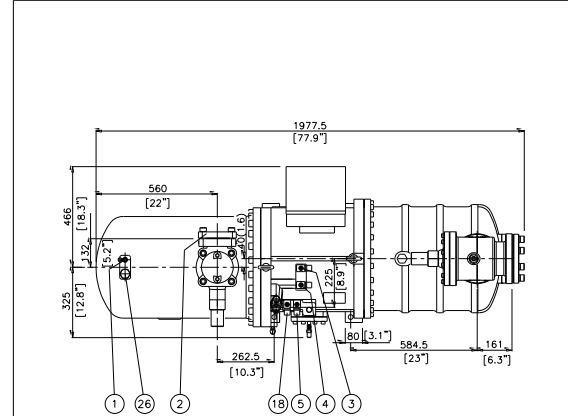

No.	Name	Note	No.	Name	Note
1	Angle valve	1/4"Flare	16	Angle valve	1/4"Flare
2	Discharge flange	4"	17	Refrigerant service valve	1/4"Flare
3	Solenoid valve	50%(NC)	18	Solenoid valve	Stepless(NC or NO), option
4	Solenoid valve	75%(NC)	19	Liquid injection connector	5/8"Flare
5	Solenoid valve	35%(NC)	20	Suction flange	5"
6	Liquid(oil or refrigerant) injection connector	3/8"Flare	21	Cable box	Standard
7	Capillary		22	Service flange	
8	Check valve	4"	23	Oil drain valve	
9	Oil flow sight glass		24	Oil level switch	
10	Oil heater	150W/300W	25	Discharge temp. sensor	110°C
11	Oil filter cartridge		26	Safety Valve	1"NPT,option
12	Oil pressure differential switch	Connector, option	27	Economizer port	1 1/8", solder
13	Oil cooler connector(out)	3/4"Flare, option	28	Oil level sight glass	
14	Stop pin	option	29	Over flow port	option
15	Oil cooler connector(in)	3/4"Flare, option			

*All stop valves are optional.

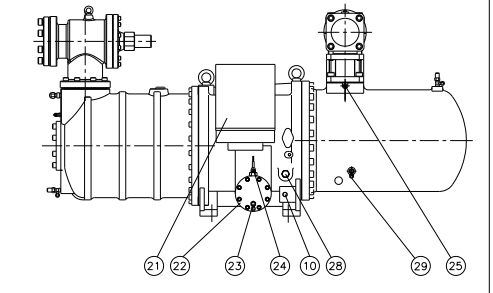
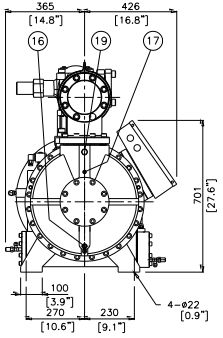
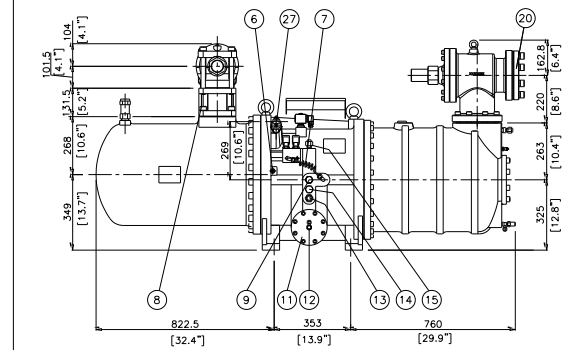

Model	RC2-710B
Name	Compressor outline
	HANBELL No. 06

UNIT:
SI: mm Imperial: (in)

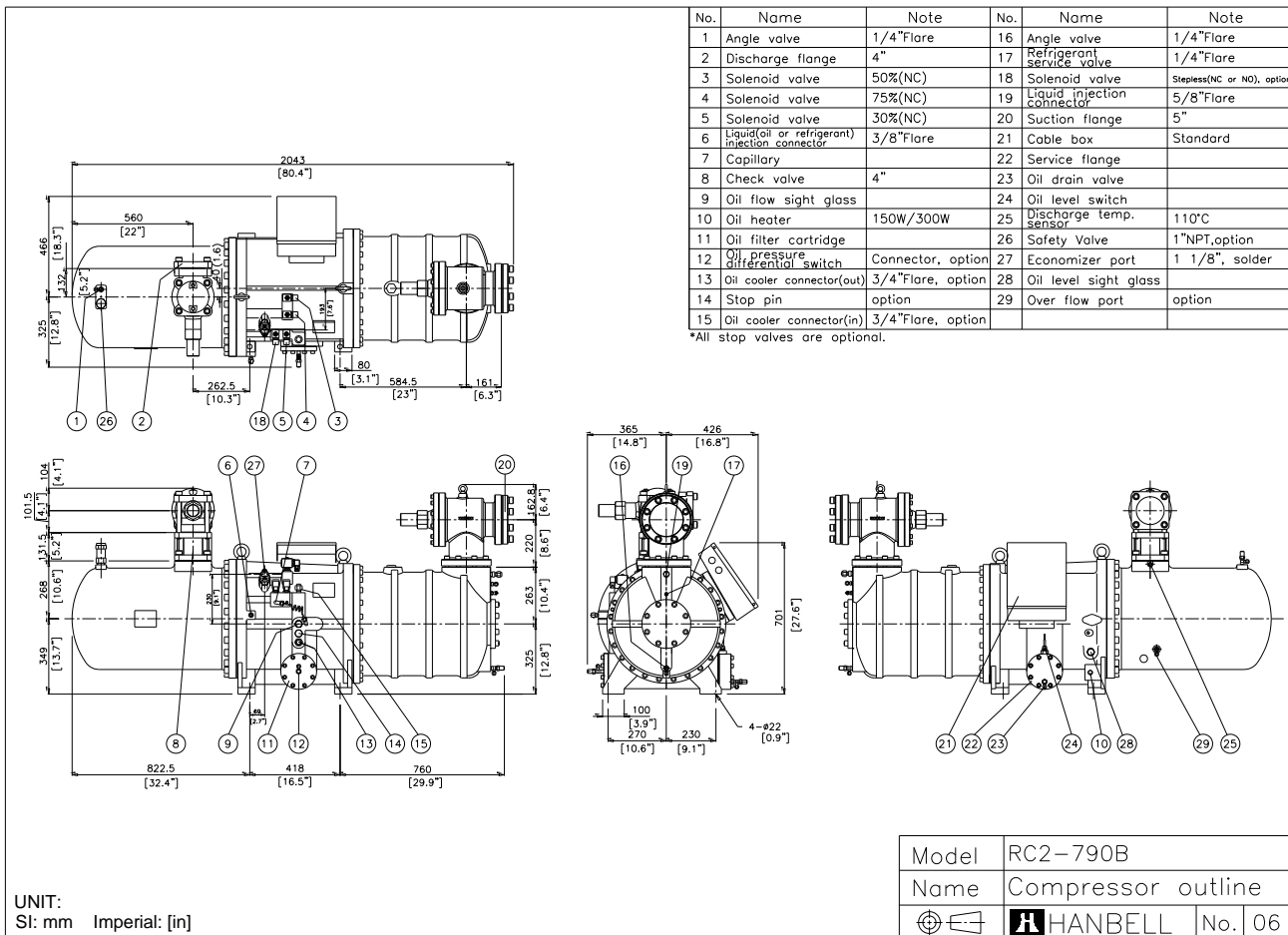

UNIT:
SI: mm Imperial: [in]

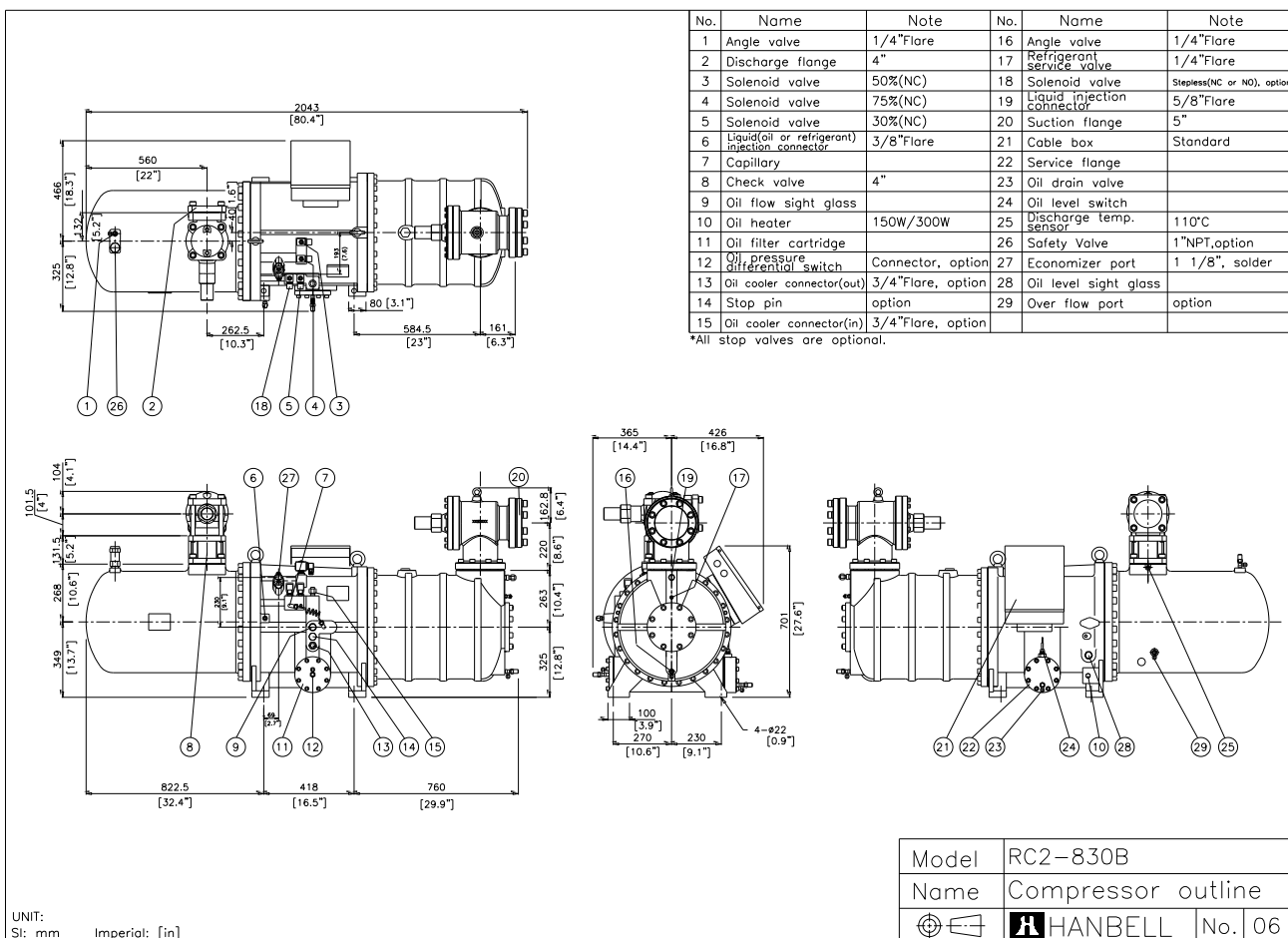

UNIT:
SI: mm Imperial: [in]

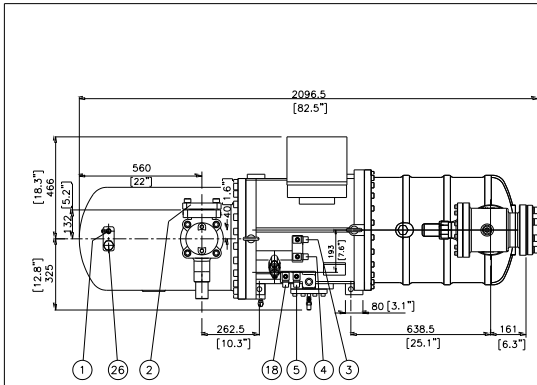

No.	Name	Note	No.	Name	Note
1	Angle valve	1/4"Flare	16	Angle valve	1/4"Flare
2	Discharge flange	4"	17	Refrigerant service valve	1/4"Flare
3	Solenoid valve	50%(NC)	18	Solenoid valve	Stepless(NC or NO), option
4	Solenoid valve	75%(NC)	19	Liquid injection connector	5/8"Flare
5	Solenoid valve	35%(NC)	20	Suction flange	5"
6	Liquid(oil or refrigerant) injection connector	3/8"Flare	21	Cable box	Standard
7	Capillary		22	Service flange	
8	Check valve	4"	23	Oil drain valve	
9	Oil flow sight glass		24	Oil level switch	
10	Oil heater	150W/300W	25	Discharge temp. sensor	110°C
11	Oil filter cartridge		26	Safety Valve	1"NPT,option
12	Oil pressure differential switch	Connector, option	27	Economizer port	1 1/8", solder
13	Oil cooler connector(out)	3/4"Flare, option	28	Oil level sight glass	
14	Stop pin	option	29	Over flow port	option
15	Oil cooler connector(in)	3/4"Flare, option			

*All stop valves are optional.

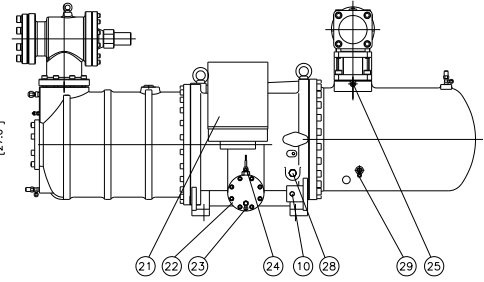
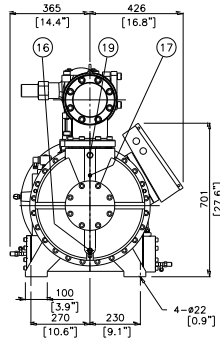
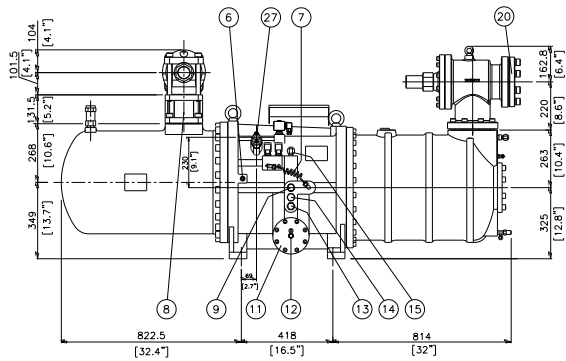

Model	RC2-930B
Name	Compressor outline
	HANBELL Ver.06

UNIT:
SI: mm Imperial: [in]

Note: For RC2-1020B, RC2-1130B, RC2-1270B and RC2-1530B outline drawing, please refer to those of RC2-1020A, RC2-1130A, RC2-1270A, and RC2-1530A

4.4 Compressors accessories

To supply "Total Solution" to customers, Hanbell designs complete standard and optional accessories according to various application requirements for safe and steady running and best performance of compressors

1. Compressors standard and optional accessories

● : Standard, Δ : Optional

Model & Accessory	RC2 -																									
	100	140	180	200	230	260	300	310	320	340	370	410	430	470	510	550	580	620	710	790	830	930	1020	1130	1270	1530
Steps or Step-less capacity control system	●	●	●	●	●	●	●	●	●	●	●	●	●	●	●	●	●	●	●	●	●	●	●	●	●	●
Compatible Steps& step-less capacity control system	Δ	Δ	Δ	Δ	Δ	Δ	Δ	Δ	Δ	Δ	Δ	Δ	Δ	Δ	Δ	Δ	Δ	Δ	Δ	Δ	Δ	Δ	Δ	Δ	Δ	Δ
Discharge check valve	●	●	●	●	●	●	●	●	●	●	●	●	●	●	●	●	●	●	●	●	●	●	●	●	●	●
Suction & discharge connection bushings	●	●	●	●	●	●	●	●	●	●	●	●	●	●	●	●	●	●	●	●	●	●	●	●	●	●
Suction & discharge stop valves	Δ	Δ	Δ	Δ	Δ	Δ	Δ	Δ	Δ	Δ	Δ	Δ	Δ	Δ	Δ	Δ	Δ	Δ	Δ	Δ	Δ	Δ	Δ	Δ	Δ	Δ
PTC temp. sensor	●	●	●	●	●	●	●	●	●	●	●	●	●	●	●	●	●	●	●	●	●	●	●	●	●	●
INT69HBY controller	●	●	●	●	●	●	●	●	●	●	●	●	●	●	●	●	●	●	●	●	●	●	●	●	●	●
IP54 cable box	●	●	●	●	●	●	●	●	●	●	●	●	●	●	●	●	●	●	●	●	●	●	●	●	●	●
150W oil heater	●	●	●	●	●	●	●	●	●	●	●	●	●	●	●	●	●	●	●	●	●	●	●	●	●	●
Oil level switch	Δ	Δ	Δ	Δ	Δ	Δ	Δ	Δ	Δ	Δ	Δ	Δ	Δ	Δ	Δ	Δ	Δ	Δ	Δ	Δ	Δ	Δ	Δ	Δ	Δ	Δ
Oil drain valve	Δ	Δ	Δ	Δ	Δ	Δ	Δ	Δ	Δ	Δ	Δ	Δ	Δ	Δ	Δ	Δ	Δ	Δ	Δ	Δ	Δ	Δ	Δ	Δ	Δ	Δ
Oil temperature sensor	Δ	Δ	Δ	Δ	Δ	Δ	Δ	Δ	Δ	Δ	Δ	Δ	Δ	Δ	Δ	Δ	Δ	Δ	Δ	Δ	Δ	Δ	Δ	Δ	Δ	Δ
Liquid injection system (solenoid valve + expansion valve)	Δ	Δ	Δ	Δ	Δ	Δ	Δ	Δ	Δ	Δ	Δ	Δ	Δ	Δ	Δ	Δ	Δ	Δ	Δ	Δ	Δ	Δ	Δ	Δ	Δ	Δ
Liquid injection system (solenoid valve + stop valve)	Δ	Δ	Δ	Δ	Δ	Δ	Δ	Δ	Δ	Δ	Δ	Δ	Δ	Δ	Δ	Δ	Δ	Δ	Δ	Δ	Δ	Δ	Δ	Δ	Δ	Δ
Horizontal check valve	Δ	Δ	Δ	Δ	Δ	Δ	Δ	Δ	Δ	Δ	Δ	Δ	Δ	Δ	Δ	Δ	Δ	Δ	Δ	Δ	Δ	Δ	Δ	Δ	Δ	Δ
External oil separator	Δ	Δ	Δ	Δ	Δ	Δ	Δ	Δ	Δ	Δ	Δ	Δ	Δ	Δ	Δ	Δ	Δ	Δ	Δ	Δ	Δ	Δ	Δ	Δ	Δ	Δ
External oil filter	Δ	Δ	Δ	Δ	Δ	Δ	Δ	Δ	Δ	Δ	Δ	Δ	Δ	Δ	Δ	Δ	Δ	Δ	Δ	Δ	Δ	Δ	Δ	Δ	Δ	Δ
Oil flow switch	Δ	Δ	Δ	Δ	Δ	Δ	Δ	Δ	Δ	Δ	Δ	Δ	Δ	Δ	Δ	Δ	Δ	Δ	Δ	Δ	Δ	Δ	Δ	Δ	Δ	Δ
Economizer	Δ	Δ	Δ	Δ	Δ	Δ	Δ	Δ	Δ	Δ	Δ	Δ	Δ	Δ	Δ	Δ	Δ	Δ	Δ	Δ	Δ	Δ	Δ	Δ	Δ	Δ
Economizer connection muffler	Δ	Δ	Δ	Δ	Δ	Δ	Δ	Δ	Δ	Δ	Δ	Δ	Δ	Δ	Δ	Δ	Δ	Δ	Δ	Δ	Δ	Δ	Δ	Δ	Δ	Δ
Oil cooler	Δ	Δ	Δ	Δ	Δ	Δ	Δ	Δ	Δ	Δ	Δ	Δ	Δ	Δ	Δ	Δ	Δ	Δ	Δ	Δ	Δ	Δ	Δ	Δ	Δ	Δ
Oil pump	Δ	Δ	Δ	Δ	Δ	Δ	Δ	Δ	Δ	Δ	Δ	Δ	Δ	Δ	Δ	Δ	Δ	Δ	Δ	Δ	Δ	Δ	Δ	Δ	Δ	Δ
Oil filter pressure differential switch connector	Δ	Δ	Δ	Δ	Δ	Δ	Δ	Δ	Δ	Δ	Δ	Δ	Δ	Δ	Δ	Δ	Δ	Δ	Δ	Δ	Δ	Δ	Δ	Δ	Δ	Δ
Safety valve	Δ	Δ	Δ	Δ	Δ	Δ	Δ	Δ	Δ	Δ	Δ	Δ	Δ	Δ	Δ	Δ	Δ	Δ	Δ	Δ	Δ	Δ	Δ	Δ	Δ	Δ
Explosion proof accessories	Δ	Δ	Δ	Δ	Δ	Δ	Δ	Δ	Δ	Δ	Δ	Δ	Δ	Δ	Δ	Δ	Δ	Δ	Δ	Δ	Δ	Δ	Δ	Δ	Δ	Δ
Mounting pad	Δ	Δ	Δ	Δ	Δ	Δ	Δ	Δ	Δ	Δ	Δ	Δ	Δ	Δ	Δ	Δ	Δ	Δ	Δ	Δ	Δ	Δ	Δ	Δ	Δ	Δ
Lubricant oil	Δ	Δ	Δ	Δ	Δ	Δ	Δ	Δ	Δ	Δ	Δ	Δ	Δ	Δ	Δ	Δ	Δ	Δ	Δ	Δ	Δ	Δ	Δ	Δ	Δ	Δ
Micro controller	Δ	Δ	Δ	Δ	Δ	Δ	Δ	Δ	Δ	Δ	Δ	Δ	Δ	Δ	Δ	Δ	Δ	Δ	Δ	Δ	Δ	Δ	Δ	Δ	Δ	Δ
Sound jacket	Δ	Δ	Δ	Δ	Δ	Δ	Δ	Δ	Δ	Δ	Δ	Δ	Δ	Δ	Δ	Δ	Δ	Δ	Δ	Δ	Δ	Δ	Δ	Δ	Δ	Δ
Temperature sensors Pt100 or Pt1000 – for motor coil temp. monitoring	Δ	Δ	Δ	Δ	Δ	Δ	Δ	Δ	Δ	Δ	Δ	Δ	Δ	Δ	Δ	Δ	Δ	Δ	Δ	Δ	Δ	Δ	Δ	Δ	Δ	Δ

Note: The accessory table is just for reference only. Actual specification and accessories enclosed might vary with different quotation and agreement respectively. If any optional accessory is required and out of above mentioned standard accessory, please contact Hanbell for detailed specification and price.



2. Description of accessories

a. Steps or step-less capacity control system

Please refer to chapter 2.6 and 2.7 for the detail of step or step-less capacity control system.

b. Compatible steps and step-less capacity control system

For customers' ease of stock control, possible modification of capacity-control logic in the future, or other special requirements of capacity control, Hanbell deliberately designs devices for stepless/step dual capacity control as nonstandard accessory for customers' choices. Logic of stepless/step dual capacity control is basically identical to those of stepless or step capacity control respectively. Please refer to Chapter 2.6, 2.7, & 2.8 for further details.

c. Suction and discharge check valve

Hanbell standard check valve (vertical type) is gravity-driven with characteristics of large flow volume and low pressure differential. After shut-down of compressor, Teflon taper guider inside can simultaneously seal up the precisely machined base of check valve by gravity force to effectively prevent return of high-pressed gas to compressor. The gravity-driven check valve is equipped vertically. Due to limitation of space or piping requirements, alternative horizontal check valve is also available.

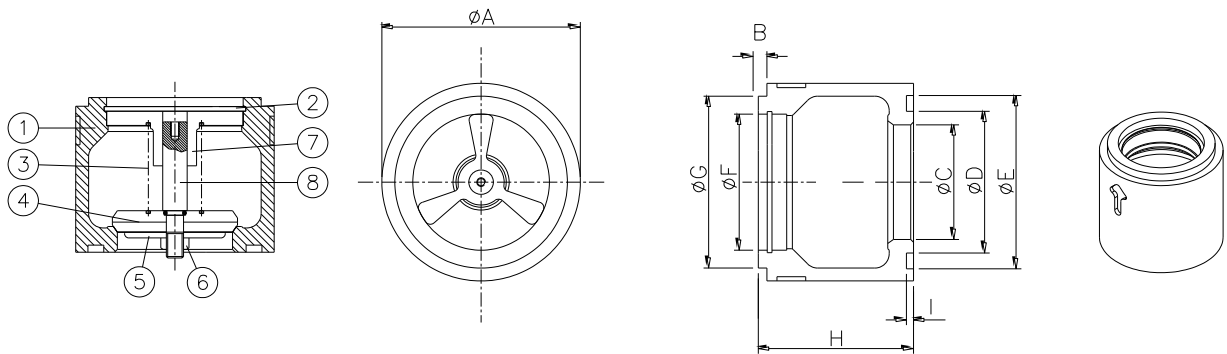

Figure 24 Suction check valve outline drawing (Horizontal type)

Dia.	Dimension								
	A	B	C	D	E	F	G	H	I
2"	102	6	53	69	91	65	90	85	5
2 1/2"	122	6	69	89	111	85	110	97	5
3"	138	6	80	99	121	95	120	108	5
4"	163	6	96	124	146	120	145	123	5

No.	1	2	3	4	5	6	7	8
Item	Body	C clipper	Spring	Valve plate	Gasket	Nut	Guide seat	Shaft

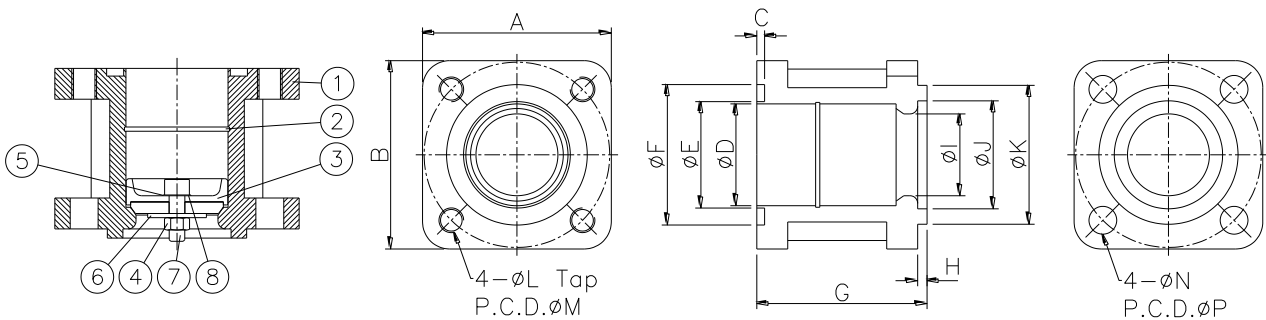

Figure 25 Discharge check valve outline drawing (Vertical type)

Dia.	Dimension														
	A	B	C	D	E	F	G	H	I	J	K	L	M	N	P
1 1/2"	109	109	5	55	59	76	105	6	34	60	75	M16x2	105	18	105
2"	122	122	5	65	69	91	110	6	46	70	90	M16x2	120	18	120
2 1/2"	134	134	5	85	89	111	125	6	55	90	110	M16x2	140	18	140
3"	153	153	5	95	99	121	135	6	66	100	120	M20x2 .5	160	22	160
4"	171	171	5	120	124	146	135	6	80.5	125	145	M20x2 .5	185	22	185

No.	1	2	3	4	5	6	7	8
Item	Body	C clipper	Guide seat	Nut	Valve plate	Gasket	Bolt	Washer

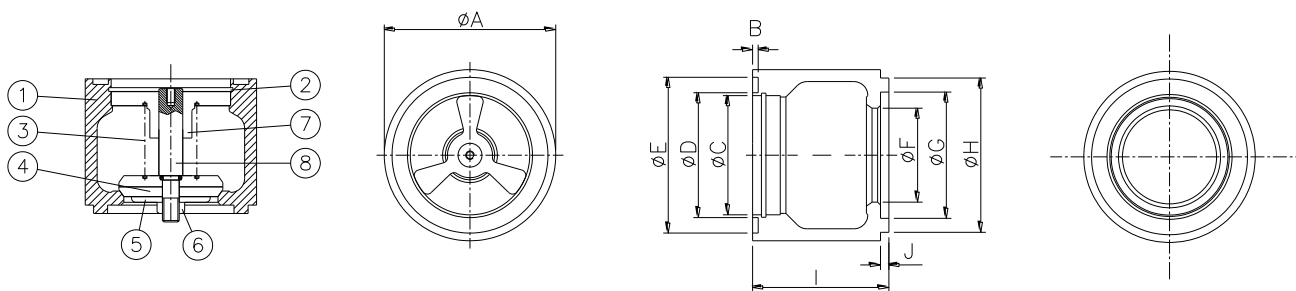
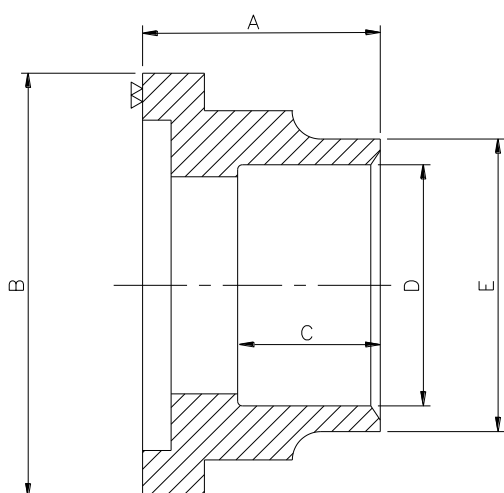

Figure 26 Discharge check valve outline drawing (Horizontal type)

Dia.	Dimension										unit: mm
	A	B	C	D	E	F	G	H	I	J	
1 1/2"	86	4	55	59	76	42	60	75	80.5	6	
2"	102	4	65	69	91	53	70	90	85	6	
2 1/2"	122	4	85	89	111	67	90	110	97	6	
3"	138	4	95	99	121	80	100	120	108	6	
4"	163	4	120	124	146	96	125	145	123	6	
6"	238	5	190	195	216	146	190	215	160	6	

No.	1	2	3	4	5	6	7	8
Item	Body	C clipper	Spring	Valve plate	Gasket	Nut	Guide seat	Shaft

d. Suction and discharge connection bushings



Model	Standard Discharge Flange Bushing		Standard Suction Flange Bushing	
	Steel pipe	Copper pipe	Steel pipe	Copper pipe
RC2-100	1 1/2"	1 5/8"	2"	2 1/8"
RC2-140	1 1/2"	1 5/8"	2"	2 1/8"
RC2-180	1 1/2"	1 5/8"	2 1/2"	2 5/8"
RC2-200	1 1/2"	1 5/8"	2 1/2"	2 5/8"
RC2-230	2"	2 1/8"	3"	3 1/8"
RC2-260	2"	2 1/8"	3"	3 1/8"
RC2-300	2"	2 1/8"	3"	3 1/8"
RC2-310	2"	2 1/8"	3"	3 1/8"
RC2-340	2 1/2"	2 5/8"	4"	4 1/8"
RC2-370	2 1/2"	2 5/8"	4"	4 1/8"
RC2-410	2 1/2"	2 5/8"	4"	4 1/8"
RC2-470	2 1/2"	2 5/8"	4"	4 1/8"
RC2-510	3"	3 1/8"	4"	4 1/8"
RC2-550	3"	3 1/8"	4"	4 1/8"
RC2-580	3"	3 1/8"	4"	4 1/8"
RC2-620	3"	3 1/8"	5"	5 1/8"
RC2-710	4"	4 1/8"	5"	5 1/8"
RC2-790	4"	4 1/8"	5"	5 1/8"
RC2-830	4"	4 1/8"	5"	5 1/8"
RC2-930	4"	4 1/8"	5"	5 1/8"
RC2-1020	4"	4 1/8"	6"	
RC2-1130	4"	4 1/8"	6"	
RC2-1270	5"		8"	
RC2-1530	5"		8"	

Figure 27 Flange bushing dimensions

Note: The above table lists specification of standard bushing for every model of Hanbell compressors. Their dimensions correspond to flange bushing dimensions and the table below. If bushing dimensions are not indicated in purchasing order, Hanbell will provide standard type. Suitable piping of customers' choice is also shown in the table below. If non-standard bushing is needed, please double-check with Hanbell sales representatives when placing order for compressors.



Specification and dimension of optional flange bushing

Model	Discharge / Suction port	Materials and Sizes of pipes		Dimension of flanges bushing				
				A	B	C	D	E
RC2-100 RC2-140	Discharge	Copper	1 5/8"	52	75	35	41.6	52
		Steel	2 1/8"				54.3	65
	Suction	Copper	1 1/2"	50	90	30	49.3	64
			1 5/8"				41.6	55
		2 1/8"	54.3				65	
		2 5/8"	67				74	
Steel	2"	61.3	74					
RC2-180 RC2-200	Discharge	Copper	15/8"	52	75	35	41.6	52
		Steel	2 1/8"				54.3	65
	Suction	Copper	1 1/2"	60	110	35	49.3	64
			2 1/8"				54.3	65
		2 5/8"	67				77	
		3 1/8"	79.8				90	
Steel	2 1/2"	77.2	90					
RC2-230 RC2-260 RC2-300 RC2-310	Discharge	Copper	1 5/8"	50	90	30	41.6	55
		Steel	2 1/8"				54.3	65
	Suction	Copper	2 1/8"	66	120	45	67	77
			2 5/8"				79.8	90
		3 1/8"	90.2				103	
		2 1/2"	77.2				92	
Steel	3"	90.2	103					
RC2-340 RC2-370 RC2-410 RC2-470	Discharge	Copper	2 1/8"	60	110	35	54.3	65
		Steel	2 5/8"				67	77
	Suction	Copper	3 1/8"	76	145	50	79.8	90
			3 5/8"				92.4	103
		4 1/8"	105.1				116	
		3"	90.2				105	
Steel	3 1/2"	102.8	117					
RC2-510 RC2-550 RC2-580	Discharge	Copper	4"	66	120	45	115.6	128
		Steel	2 1/8"				54.3	65
	Suction	Copper	2 5/8"	76	145	50	67	77
			3 1/8"				79.8	90
		4 1/8"	90.2				103	
		3"	77.2				92	
Steel	3 1/2"	102.8	117					
RC2-620	Discharge	Copper	4"	66	120	45	115.6	128
		Steel	2 1/8"				54.3	65
	Suction	Copper	2 5/8"	80	174	35	67	77
			3 1/8"				79.8	90
		4 1/8"	90.2				103	
		3"	77.2				92	
Steel	5 1/8"	105.1	121.2					
RC2-710 RC2-790 RC2-830 RC2-930	Discharge	Copper	5"	75	174	35	130.5	146.5
		Steel	3 1/8"				79.8	90
	Suction	Copper	3 5/8"	80	174	35	92.4	103
			4 1/8"				105.1	116
		3"	90.2				105	
		3 1/2"	102.8				117	
Steel	4"	115.6	128					
RC2-1020 RC2-1130	Discharge	Copper	4 1/8"	76	145	50	105.1	116
		Steel	5 1/8"				130.5	146.5
	Suction	Copper	5"	75	215	40	141.3	154
			3 1/8"				79.8	90
		3 5/8"	92.4				103	
		4 1/8"	105.1				116	
Steel	3"	90.2	105					
RC2-1270 RC2-1530	Discharge	Steel	3 1/2"	75	260	40	102.8	117
	Suction	Steel	6"				115.6	128
	Discharge	Steel	5"	75	260	40	166.7	196
	Suction	Steel	8"				141.3	154

e. Suction and discharge stop valves

For maintenance and service of compressor, it is recommended to install the suction and discharge stop valves.

Please refer to following detail of Hanbell stop valves.

Model	Stop Valve Size		Model	Stop Valve Size	
	Discharge	Suction		Discharge	Suction
RC2-100	1 1/2"	2"	RC2-510	3"	4"
RC2-140	1 1/2"	2"	RC2-550	3"	4"
RC2-180	1 1/2"	2 1/2"	RC2-580	3"	4"
RC2-200	1 1/2"	2 1/2"	RC2-620	3"	5"
RC2-230	2"	3"	RC2-710	4"	5"
RC2-260	2"	3"	RC2-790	4"	5"
RC2-300	2"	3"	RC2-830	4"	5"
RC2-310	2"	3"	RC2-930	4"	5"
RC2-340	2 1/2"	4"	RC2-1020	4"	6"
RC2-370	2 1/2"	4"	RC2-1130	4"	6"
RC2-410	2 1/2"	4"	RC2-1270	5"	8"
RC2-470	2 1/2"	4"	RC2-1530	5"	8"

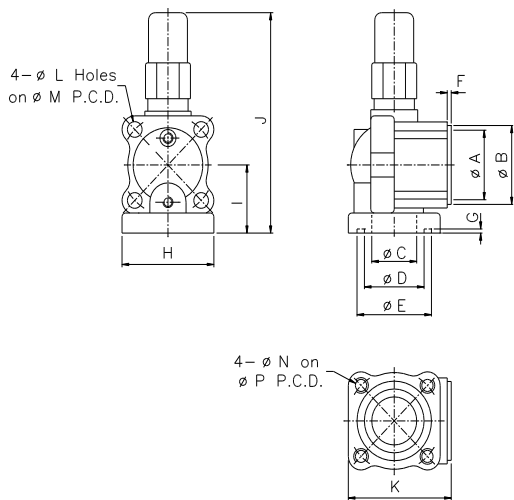

Figure 28 Dimension of stop valve

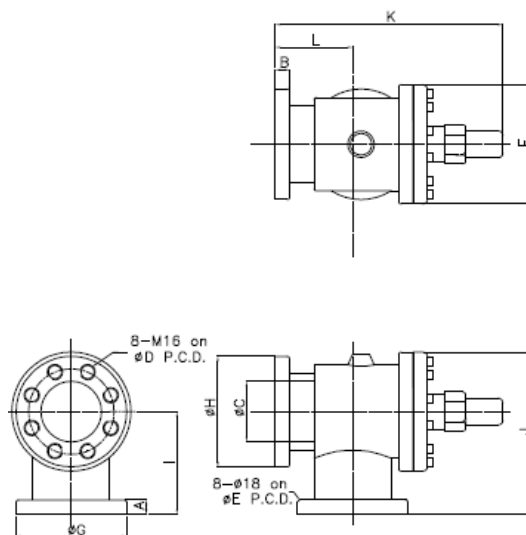

Figure 29 5" Suction stop valve

Dia.	Dimensions											unit: mm				
	A	B	C	D	E	F	G	H	I	J	K	L	M	N	P	
1 1/2"	60	75	36	59	76	6	5	106	75	256	115	18	105	M16x2	105	
2"	70	90	60	69	91	6	5	122	86	280	128	18	120	M16x2	120	
2 1/2"	90	110	67	89	111	6	5	137	95	307	153	18	140	M16x2	140	
3"	100	120	80	99	121	6	5	154	117	398	177	22	160	M20x2.5	160	
4"	125	145	105	124	146	6	5	171	130	445	201	22	185	M20x2.5	185	

Dia.	Dimensions											unit: mm	
	A	B	C	D	E	F	G	H	I	J	K	L	
5"	30	30	126	194	194	248	230	230	214	338	474	161	

* Specification of stop valve

Maximum working pressure	Hydrostatic pressure test	Refrigerant	Temperature range
28 kg / cm ² G	42 kg / cm ² G	HFC, HCFC, R717	-40°C~150°C

f. INT69HBY control module and PTC temperature sensor

In order to protect compressor, each RC2 series compressor has been installed three PTC temperature sensors inside motor coil and another one at the discharge side of compressor. These sensors are connected to an INT69HBY control module to monitor the motor and discharge temperature. If the temperature in one of the positions monitored exceeds the nominal response temperature of the respective PTC thermistor, the sensor resistance increases and the INT69HBY control module output relay trips. The module resets when the temperature drops below the response temperature by approx. 5K. The output relay provides a potential-free change-over contact and is energized as long as the nominal response temperature is not exceeded.

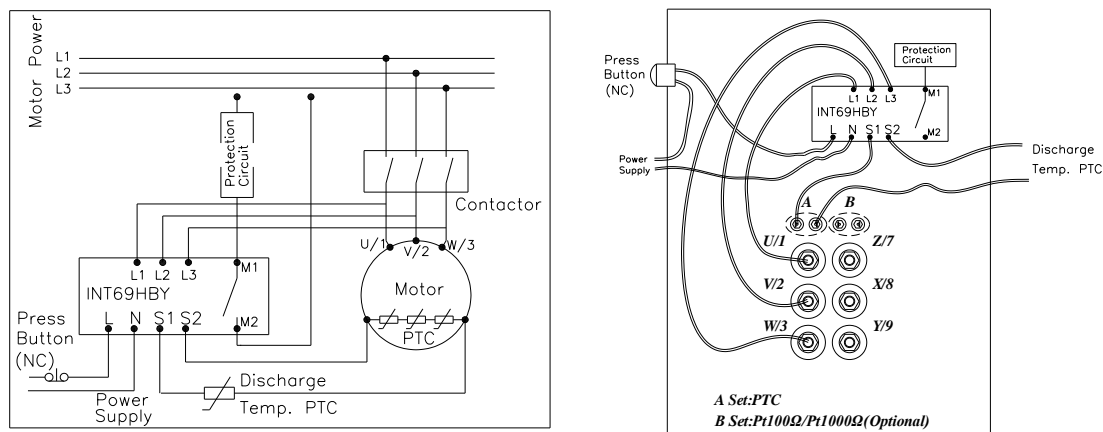

Figure 30 INT69HBY & PTC connection diagram



Other major functional descriptions are as follow:

1. After the supply voltage has been connected, a three second initialization period follows. Provide the PTC chain resistance is below the reset threshold (2.75kΩ), the relay trips after these 3 seconds have expired.
2. 1 to 9 PTC thermistors with different nominal response temperature may be connected serially to the PTC input.
3. If any thermistor resistance increases above trip level the relay drops out. This failure results in a lockout. (5 minutes delay for 1st PTC failure, 60 minutes delay for 2nd failure, lockout for 3rd failure.)
4. If a rapid temperature increase is detected (locked rotor condition), the output relay drops out. This failure results in a lockout.
5. The phase monitoring of the three phase motor voltage becomes active 1 second after motor has started, for duration of 10 seconds. In case of a wrong phase sequence or a phase failure, the relay switches off and locks.
6. The Lock-out and delay time may be lifted by cycling the power off for approx. 5 seconds.
7. To avoid nuisance tripping due to reverse running after shutdown (pressure equalization), the phase monitoring function is only re-enabled approx. 20 seconds after motor stop.
8. A dual LED (red / green) provides additional information about the motor protector and compressor status.
9. The relay is fed out as a N/O dry contact, which is closed under good conditions.
10. Sensor and supply circuits are galvanic isolated.
11. The motor protector is not suitable for application of frequency converters.

Technical data:

- Supply voltage
 - AC 50/60 Hz 115/120V-15 ...+10% 3VA
 - AC 50/60 Hz 230/240V-15...+10% 3VA
- Ambient temperature
 - 30 ... +70 °C
- Relay output
 - max. AC 240V, max. 2.5A, C300
 - min. > 24V AC/DC, >20 mA
- Phase monitor
 - 3 AC, 50/60Hz, 200 ~ 575 V ± 10%

Blink code display& diagram:

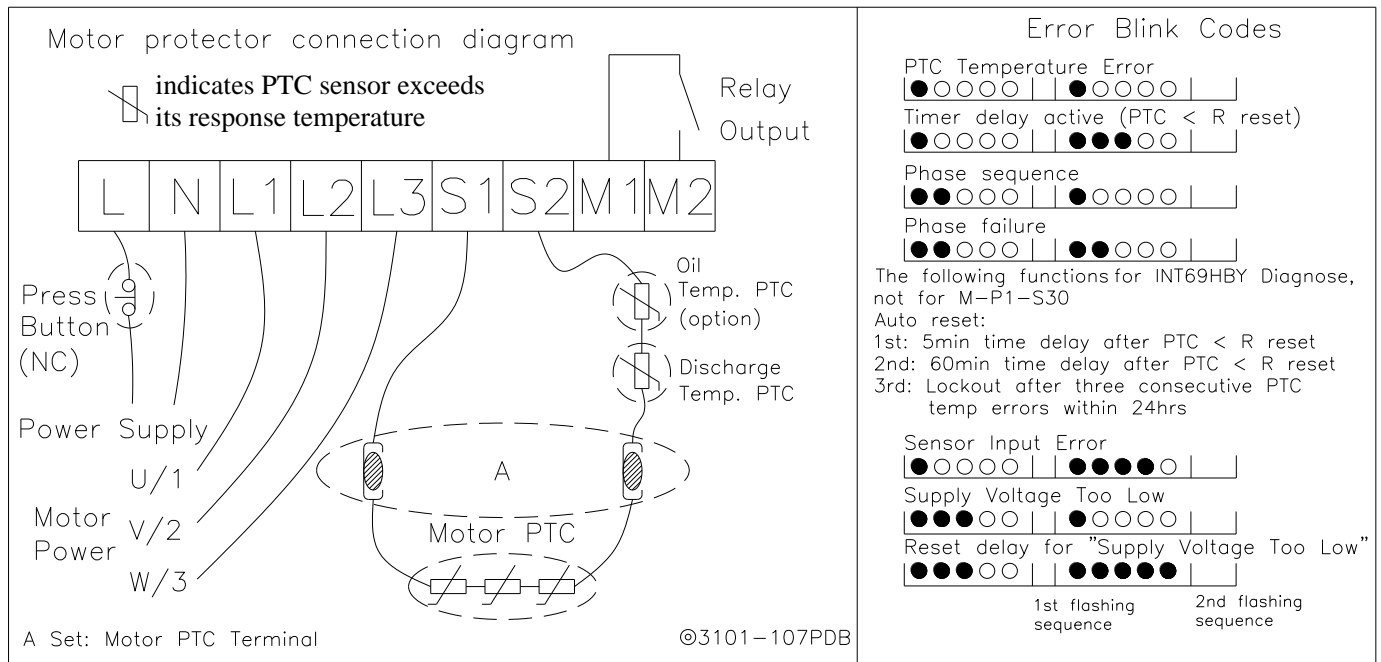

g. 150W oil heater

An UL approved 150W oil heater has been installed in every compressor as a standard accessory. Before restart of compressor after shutdown for a long time, please turn on oil heater at least 8 hours to make the temperature inside compressor higher than system temperature and ambient temperature and then it can prevent condensation of refrigerant inside oil sump of compressor which may result in liquid compression in next start and poor lubrication due to too low viscosity of lubricant oil. In addition, Hanbell also offers 300W oil heater to keep adequate lubricant oil temperature for large external oil separator and applications in areas with low ambient temperature.

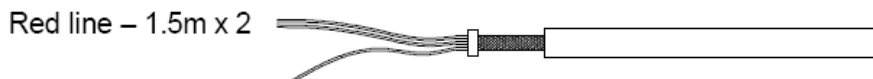

Green / Yellow line – 1.5m x 1 (Grounding)

Figure 31 150W oil heater

Specification : 150W, 300W; 110V or 220V; IP 54; UL approval

Note: If compressor is installed in low ambient temperature, it is recommended to insulate oil separator against cold ambience.

h. Oil level switch

There are 2 wires for the interlock to main control circuit or any micro controller's independent circuit. To prevent from oil level switch trip caused by oil foaming or surging in the sump, a time delay around 10 ~ 15 seconds is recommended before shut down the compressor.

Max. contact capacity = 50W/SPST
 Surge current = 0.5A
 Max. voltage = 200V DC/ 240V AC
 Max. current = 1A

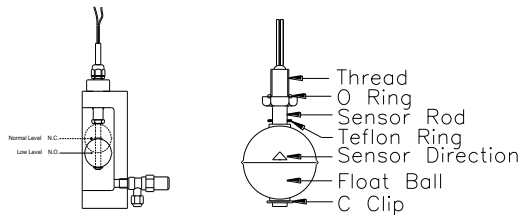

Figure 32 Oil level switch

Note:

1. On the float ball there is a triangle mark which tells you its sensor direction. Therefore, before you install an oil level switch on a compressor or an external oil separator, please use the triangle mark as your reference before install any oil level switch on the compressor or external oil separator.
2. Please check this triangle mark and modify the oil level switch if needed.
3. If you have any other question, don't hesitate to contact with Hanbell representatives for help.
4. The illustration below show you the outside appearance of our oil level switch

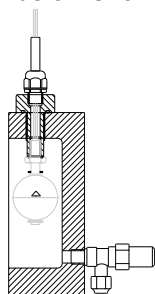

Figure 33 Oil level switch on a compressor

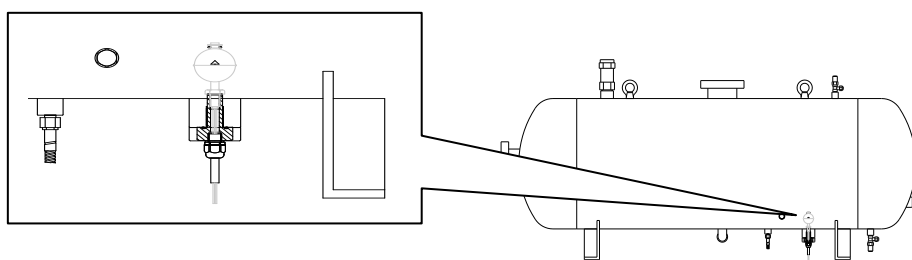

Figure 34 Oil level switch on an external oil separator

i. Oil drain valve

Oil drain valve is installed in compressor to drain out oil for maintenance.

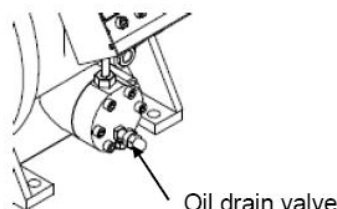

Figure 35 Oil drain valve

j. IP54 cable box

Hanbell designs and makes the cable box which meets IP54 protection degree.

Dimensions of cable box and the size of opening in cable box (for motor power line and control power line) refer to the drawing below

① RC2-100, RC2-140, RC2-180 cable box (Figure 36)

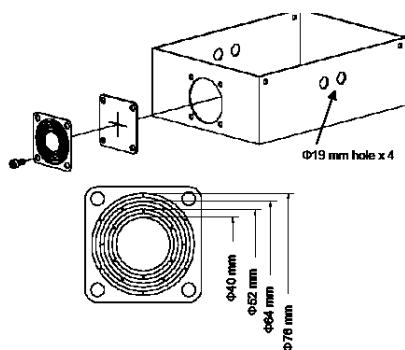

② RC2-200, RC2-230, RC2-260, RC2-300, RC2-310, RC2-340, RC2-370, RC2-410, RC2-470, RC2-510, RC2-550, RC2-580, RC2-620 cable box (Figure 37)

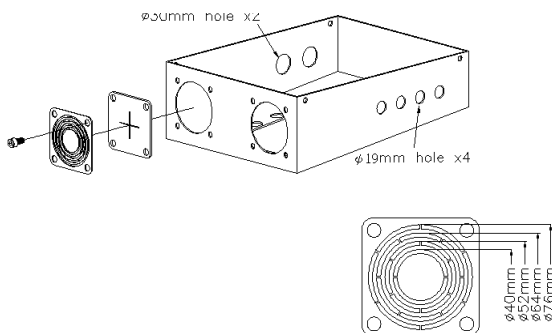



③ RC2-710, RC2-790, RC2-830, RC2-930 cable box (Figure 38)

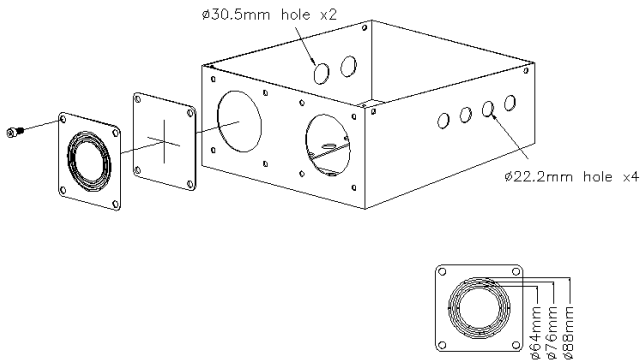

④ RC2-1020, RC1130, RC1270, RC2-1530 cable box (Figure 39)

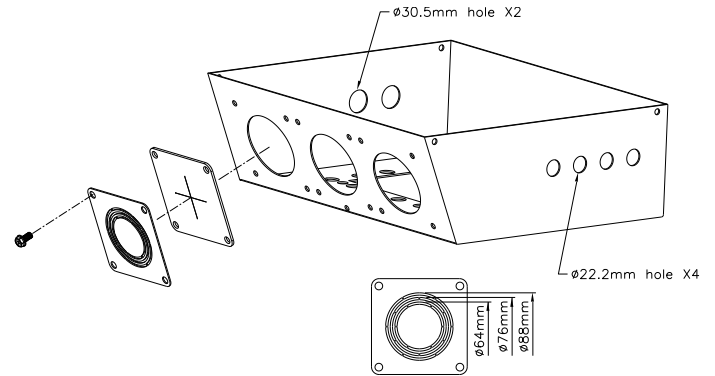

k. Liquid injection system (solenoid valve + expansion valve)

In high-condensing-temperature or low-evaporating-temperature applications liquid injection system is recommended to cool motor coil auxiliary. In high-compression-ratio applications, liquid injection system to compression chamber is also recommended to cool down high compression heat due to high compression ratio to maintain normal discharge temperature. Please refer to Chapter 7 for detailed introduction of additional cooling.

Hanbell provides the following liquid injection expansion valves and solenoid valves for customers' options. Please refer to capacity recommended in selection program to choose appropriate liquid injection expansion valves.

Brand	Model	Low Temp. Type	High Temp. Type
SPORLAN	Y1037-FV-3-180.3/8"SAE		○
	Y1037-FV-5-180.3/8"SAE		○
ALCO	TCLE-3HW-6A	○	
	TCLE-5HW-6A	○	
	TCLE-10HW-6A	○	
FUJIKOKI	JBE-E60HFKT-1		○

l. Liquid injection system (solenoid valve + stop valve)

This simple liquid injection system adjusts amount of liquid injection by stop valve, suitable for application with level load and ambient temperature but it's not recommended. Opening ratio of stop valve could not vary with system loading and change of temperature. Therefore, frequent check of discharge temperature can prevent damage of compressor due to over cooling or insufficient cooling.

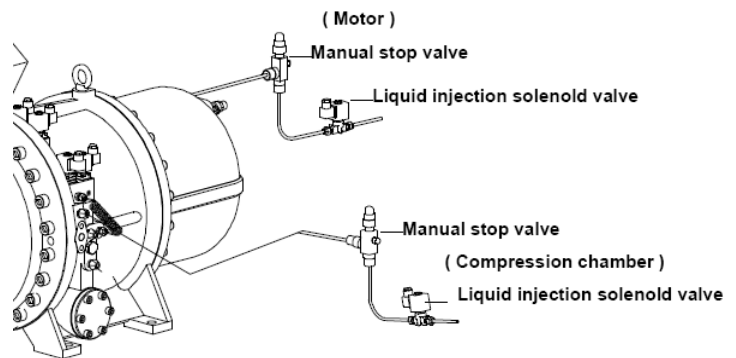

Figure 40 Liquid injection – solenoid valve + stop valve

m. Horizontal check valve installation

Horizontal check valve is standard accessory of RC2-F Series compressor. Considering limitation of clearance for installation, horizontal check valve would be alternative to aforementioned vertical check valve for RC2 Series compressor. Please refer to section C. for dimension of horizontal check valve. The installation drawing is as below:

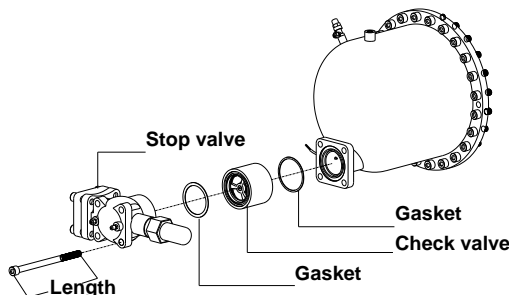

Figure 41 Dimensions and installation of horizontal check valve

n. External oil separator

For improvement of oil return in flooded-type, low-temperature and parallel systems, and system with long piping, Hanbell specially designs a complete series of external oil separators – OS series with characteristics of high filtration efficiency and low pressure drop. The following table shows details of OS series:

Note : It is recommended to install a buffer before the external oil separator to avoid noise and vibration which caused by resonance.

(I) Technical data :

Model	Type	Oil Volume (Liter)		Range of application based on Displacement (m ³ /hr) (Recommended)	Shell Diameter
		High level	Low level		
OS40	Vertical	17	9	205	14"
OS50	Vertical	22	12	206~270	16"
OS65	Vertical	31	18	271~440	18"
OS80	Horizontal	33	20	441~705	20"
OS100	Horizontal	40	27	706~1120	20"
OS125	Horizontal	50	30	1121~1310	24"
OS150	Horizontal	60	36	1311~1835	24"

(II) Accessories :

No.	Description	OS40	OS50	OS65	OS80	OS100	OS125	OS150
1	Refrigerant inlet	1 1/2"	2"	2 1/2"	3"	4"	5"	6"
2	Refrigerant outlet	1 1/2"	2"	2 1/2"	3"	4"	5"	6"
3	Oil outlet	5/8" Flare	5/8" Flare	5/8" Flare	1" PF	1" PF	1 1/4" PF	1 1/4" PF
4	Oil charge valve	1/4" Flare						
5	High oil S.G.	1 PCS						
6	Low oil S.G.	1 PCS						
7	Oil level switch	1 PCS						
8	Oil heater	150W	150W	150W	150W	150W	300W	300W
9	Oil drain valve	1/4" Flare						
10	Oil temp. protection (option)	1/8" NPTF						
11	Safety valve (option)	1/2"	1/2"	1/2"	1"	1"	1 1/2"	1 1/2"

(III) Dimensions :

No.	OS40	OS50	OS65	OS80	OS100	OS125	OS150
A	930	1050	1110	1297	1637	1829	2229
B	505	585	595	650	1000	1080	1480
C	240	275	300	359	354	409	409
D	300	350	350	300	300	400	400
E	18	22	22	23	23	23	23
F	320	360	360	688	698	830	830

(IV) Drawing :

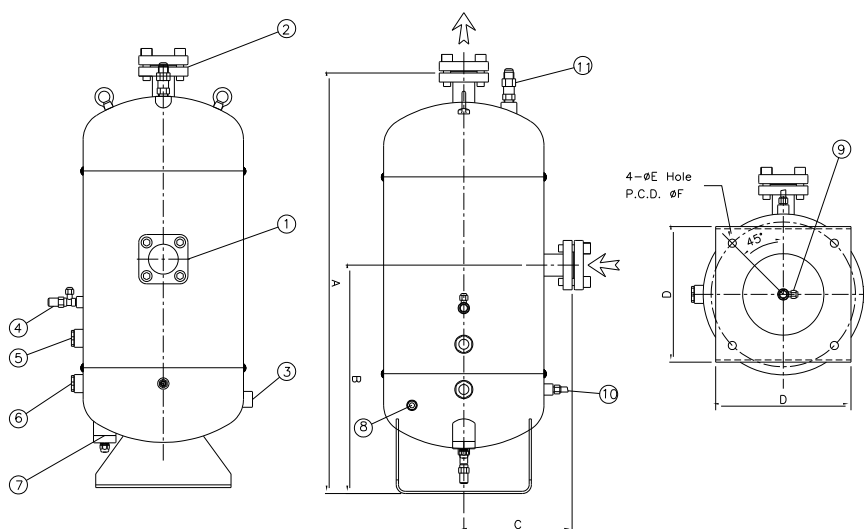

Vertical -OS40, OS50, OS65 (Figure 42)

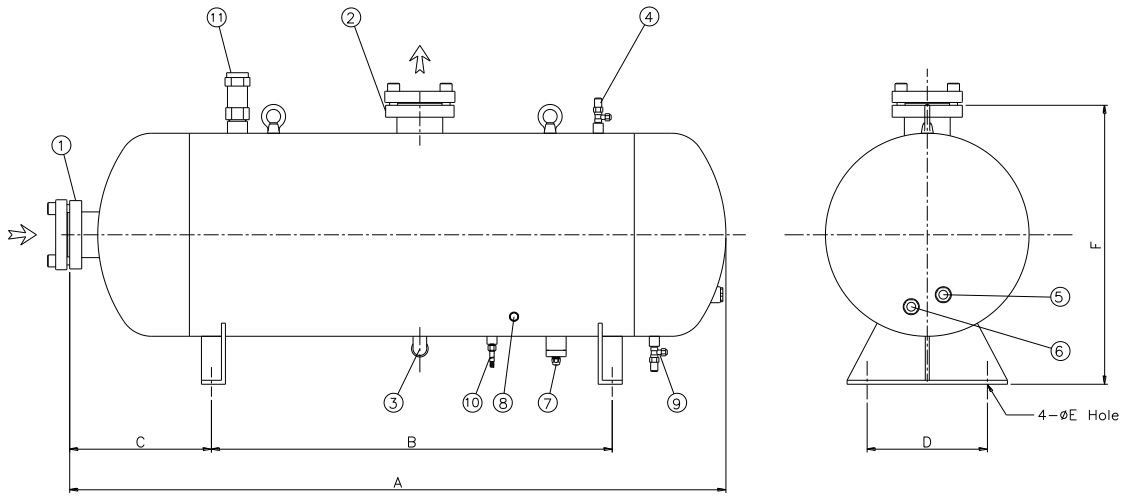

Horizontal OS80, OS100, OS125, OS150 (Figure 43)

o. External oil filter

External oil filter is optional accessory of external oil separator. It is suggested to install external oil filter in oil return line before oil inlet port of compressor for safe running of compressor.

Specification:

*Flow Rate: max 50 (l/m)		*Weight: 1.4KG/Set	
*Working Pressure: 40 bar		(the weight is not including element)	
*Material: Aluminum alloy		*Operating Temp.: from -25°C to 110°C	
*Seal: VITON			
Compressor Model	Material Code	Inlet Size	Outlet Size
RC2-100/140/180/200 230/260/300/310/340 /410/470/510	3130-3240AA	5/8"	5/8"
RC2-550/580/620/710/790 /830/930/1020/1130/1270/ 1530	3131-3240AA	3/4"	3/4"

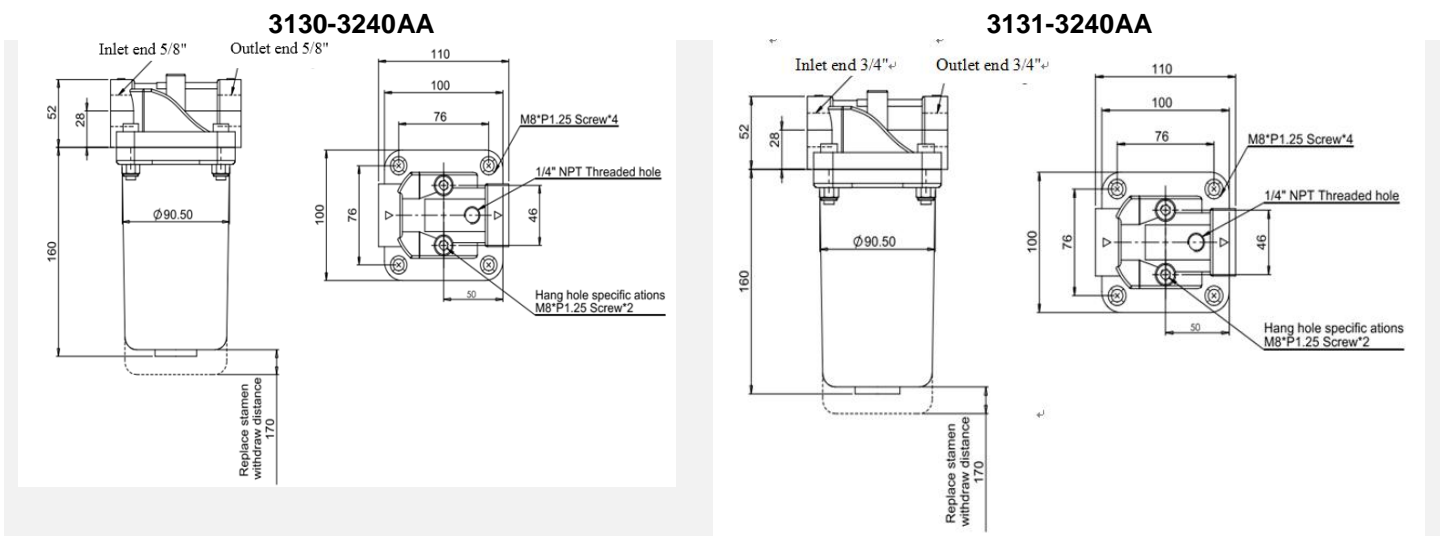

Figure 44 External oil filter

p. Oil flow switch

Oil flow switch operates with external oil separator to prevent oil deficient compressor. Specification and installation of oil flow switch are shown as below:

	G	Type	PN bar	Qmax. Recom. l/min	switch value l/min selectable range for fixed switch	L mm	H mm	SW mm	X mm	Weight kg
bronze	G 1/2	FF-015GR012	200	20	0.4-12	68	79	29	13	0.6
	G 3/4	FF-020GR025	25	40	0.6-25	73	79	32	11	0.7
	G 1	FF-025GR040	25	60	1.5-40	87	90	41	14	1

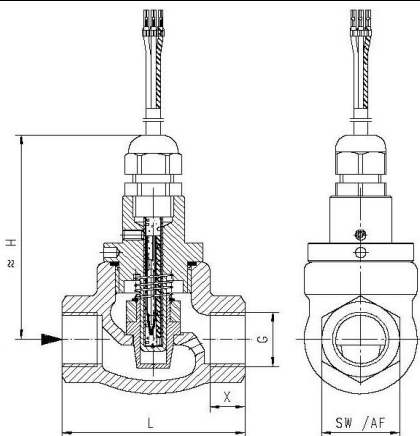

Figure 45 Outline of oil flow switch

- (1) Tolerance: ± 0.3 l/min
 - (2) Media temperature: max 110 °C
 - (3) Average pressure loss: 0.4 bar at Qmax
 - (4) Hysteresis: depending on switch value minimum 0.4 l/min
- Note: Switch value is indicated for horizontally decreasing flow

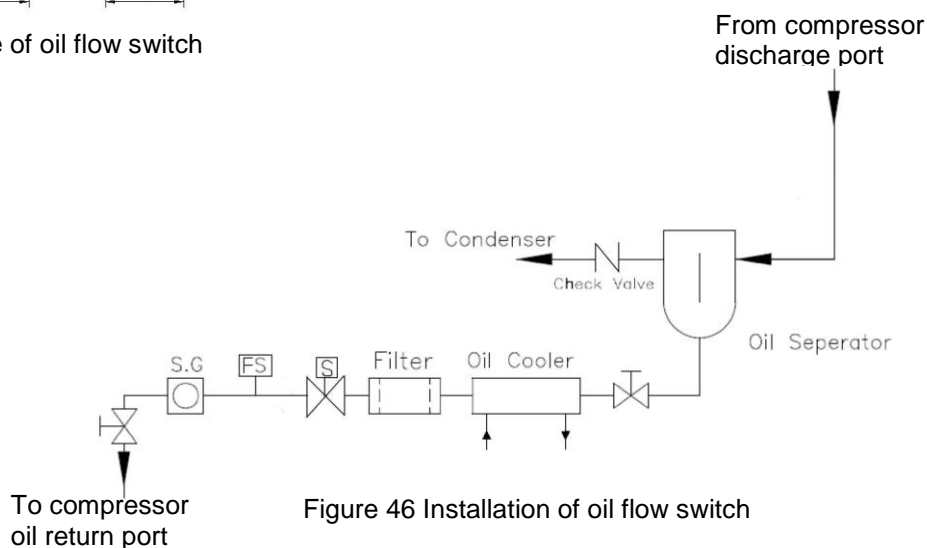

Figure 46 Installation of oil flow switch

q. Economizer connection muffler

When economizer is used, it is recommended to install a muffler and check valve before middle-pressure returned gas port in compression chamber to effectively mitigate pulsation noise in middle pressure as shown in the drawing below:

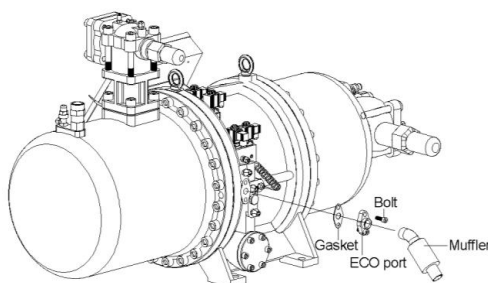

Figure 47 Installation of ECO muffler

r. Mounting pad

To avoid extra vibration and noise resulted from direct contact between compressor footings and the base on which compressor is mounted, it is recommended to add mounting pads in between as the drawing below shown.

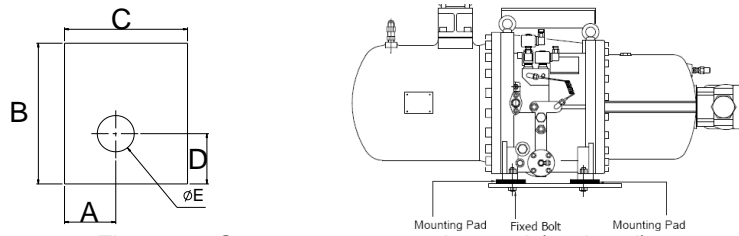

Figure 48 Compressor mounting pad (optional)

Model	Part No.	A	B	C	D	E	Thickness	Req. Qty
RC2-100, RC2-140, RC2-180, RC2-200, RC2-230, RC2-260, RC2-300, RC2-310	3131-9815B	20	55	50	20	22	20 mm	4
RC2-340, RC2-370, RC2-410, RC2-470, RC2-510, RC2-550, RC2-580	3136-9815B	26	100	70	25	22	20 mm	4
RC2-620, RC2-710, RC2-790, RC2-830, RC2-930	3139-9815B	25	100	80	25	22	20 mm	4
RC2-1020, RC2-1130, RC2-1270, RC2-1530	3142-9815B	40	100	80	40	22	20 mm	4

s. Temperature sensors Pt100 or Pt1000

RC2 models utilize suction return gas to cool down the motor coil. To effectively detect temperature of motor coil and adequately adjust volume of liquid injection by measured temperature, Hanbell specially mounts Pt100 or Pt1000 sensor on motor coil as an optional accessory. This temperature sensor along with controller of the system monitor motor coil temperature and then control on/off of liquid injection valve accordingly to provide suitable liquid injection as shown in the diagram below.

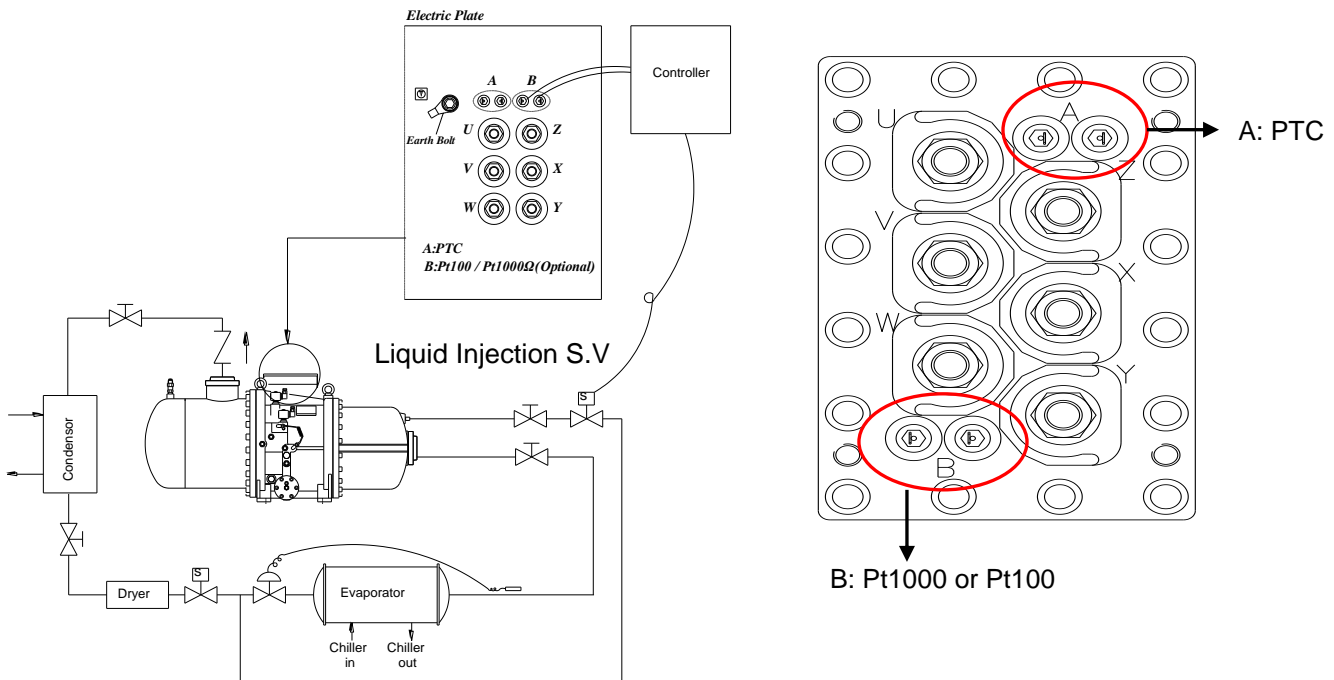

Figure 49 Liquid injection connection diagram

- Note: Hanbell suggests to control temperature of motor coil at 60°C (not higher than 60°C)
- On the terminal cover plates, "A" is PTC sensor, and "B" is Pt1000 or Pt100 temperature sensor.
- The terminal cover plates for models RC2-710B, RC2-790B, RC2-830B, RC2-930A, RC2-930B are shown above. The PTC sensor is on the top right side and Pt1000 or Pt100 is on the left bottom side of terminal cover plate.

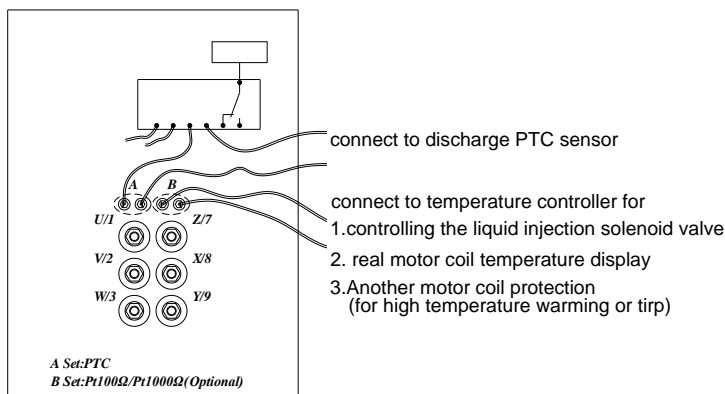

Figure 50 Connection diagram of Pt100/Pt1000 sensor

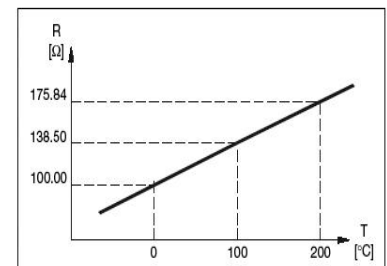

Figure 51 Pt100 sensor

Specification : Pt100 sensor

- Recommended max. meas. Current for heat coefficient $<0.1\text{K}$ - DC 1 ~ 3 mA
- Heating coefficient - $10\text{m}\Omega/\text{K}$
- Sensor resistance at 0°C - $100\Omega \pm 0.12\Omega$
- Change of resistance $0 \sim 100^\circ\text{C}$ - $0.385\Omega/\text{K}$
- Insulation test voltage U is – AC 1.5kV

Specification : Pt1000 sensor

- Recommended max. meas. Current for heat coefficient $<0.1\text{K}$ – DC 0.2 ~ 2mA
- Sensor resistance at 0°C - $1000\Omega \pm 1.20\Omega$
- Change of resistance $0 \sim 100^\circ\text{C}$ - $3.85\Omega/\text{K}$
- Insulation test voltage U is – AC 1.5kV

Note: Please specify Pt100 or Pt1000 sensor when placing orders to Hanbell.

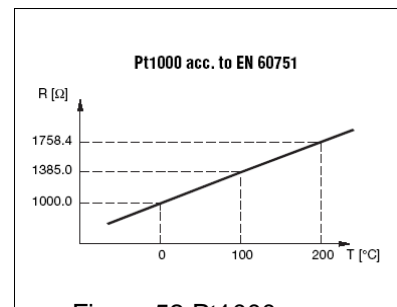

Figure 52 Pt1000 sensor



Minimum pressure valve(MPV)

Minimum pressure valve is useful in cold start condition. During the cold start period, because the system's condensing temperature is still low, the discharge pressure will stay at a quite low level which means the pressure differential between discharge and suction side will not be enough for compressor to act normally. Under such working condition, compressor might have difficulties to load itself. Oil supply to bearings and internal cooling might be not enough which will cause severe damage to those moving parts in the end. With minimum pressure valve, the pressure differential can be built shortly after the start up, so the capacity control and oil supply to those moving parts won't be a problem. Therefore, the compressor protection can be achieved. In addition to protection function, it can also act as check valve to reduce the reverse running time after compressor's stopping.

Flange on minimum pressure valves are provided for the ease of installation. It can be installed on either compressor's discharge port or external oil separator's discharge port (F type compressor only). The installation and specification are shown as below:

external equalizer tube connect to low pressure side

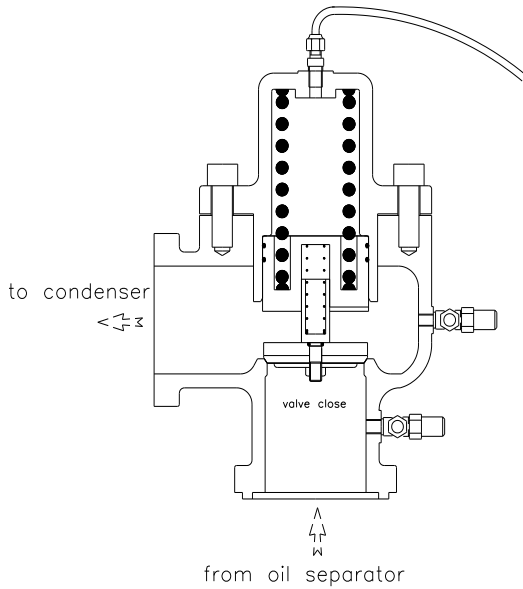

Model	Opening pressure	Max. pressure	Working temperature	Pressure drop
1 1/2"	3.6±0.3Bar	28Bar	<120°C	<0.1Bar
2"				
2 1/2 "				
3"				
4"				
6"				

Please consult Hanbell representatives for the detailed outline and application

Figure 53 Installation of MPV

4.5 Installation and connection of compressor

The diagrams below show the installation and connection of compressors

a. RC2-100, RC2-140, RC2-180

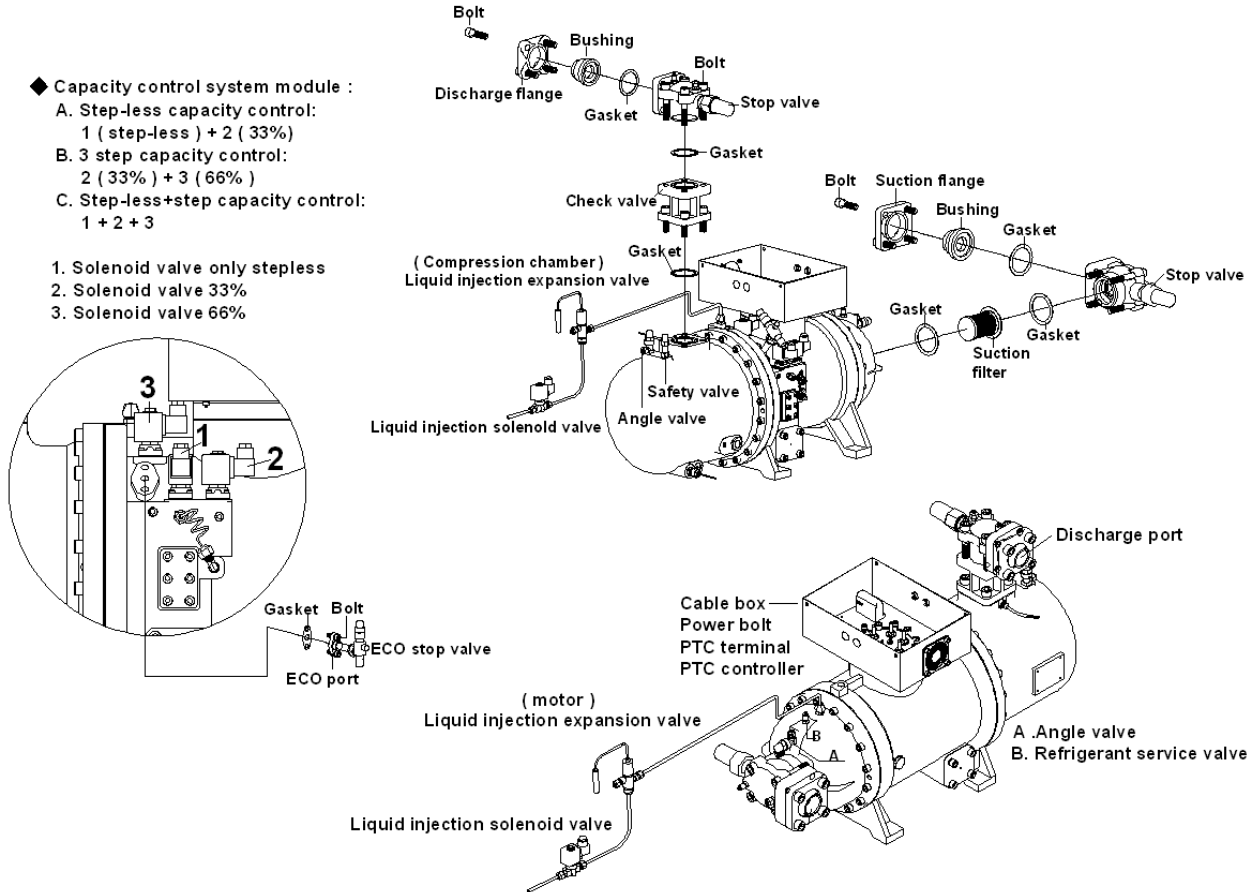

b. RC2-200, RC2-230, RC2-260, RC2-300, RC2-310, RC2-340, RC2-370, RC2-410, RC2-470, RC2-510, RC2-550, RC2-580, RC2-620

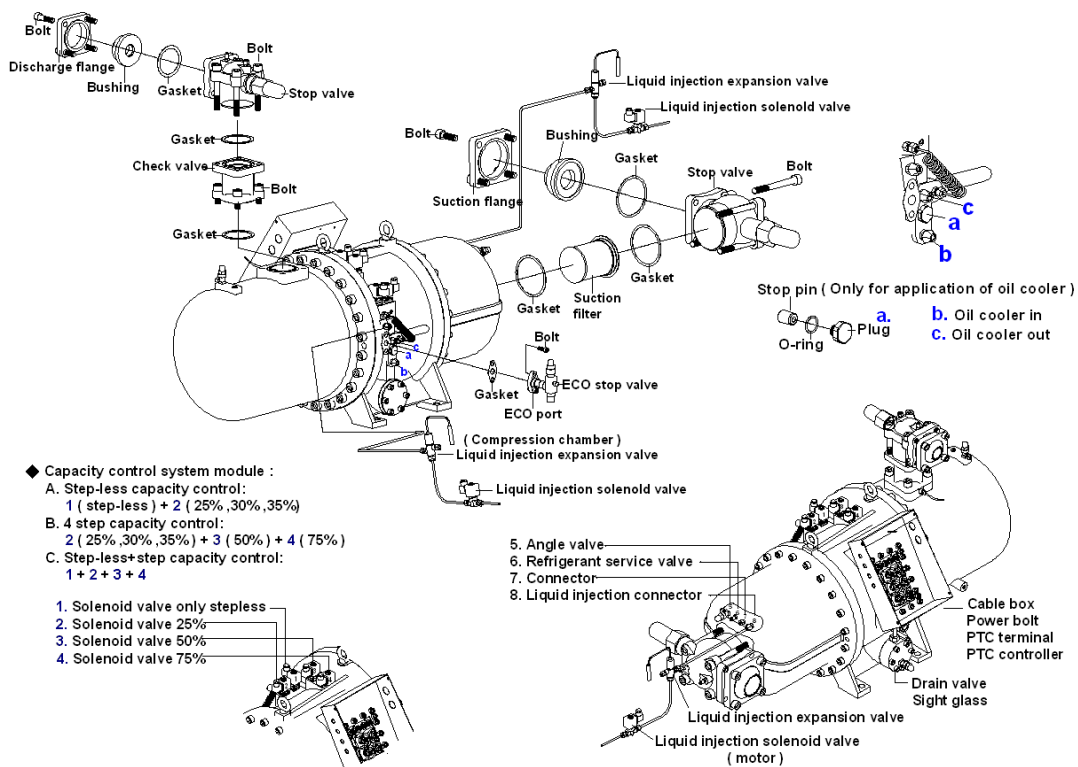



c. RC2-710, RC2-790, RC2-830, RC2-930

◆ Solenoid valve description :

1. Solenoid valve (only step-less)
2. Solenoid valve (25% ,30% ,35%)
3. Solenoid valve (50%)
4. Solenoid valve (75%)

◆ Capacity control system module :

- A. Step-less capacity control:
1 (step-less) + 2 (25% ,30% ,35%)
- B. 4 step capacity control:
2 (25% ,30% ,35%) + 3 (50%) + 4 (75%)
- C. Step-less+step capacity control:
1 + 2 + 3 + 4

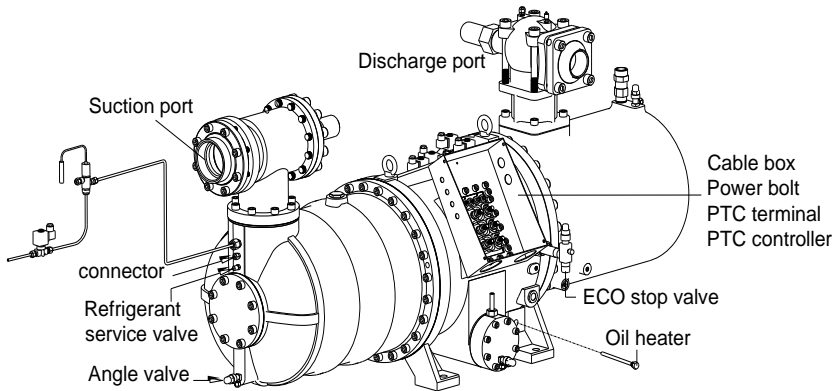
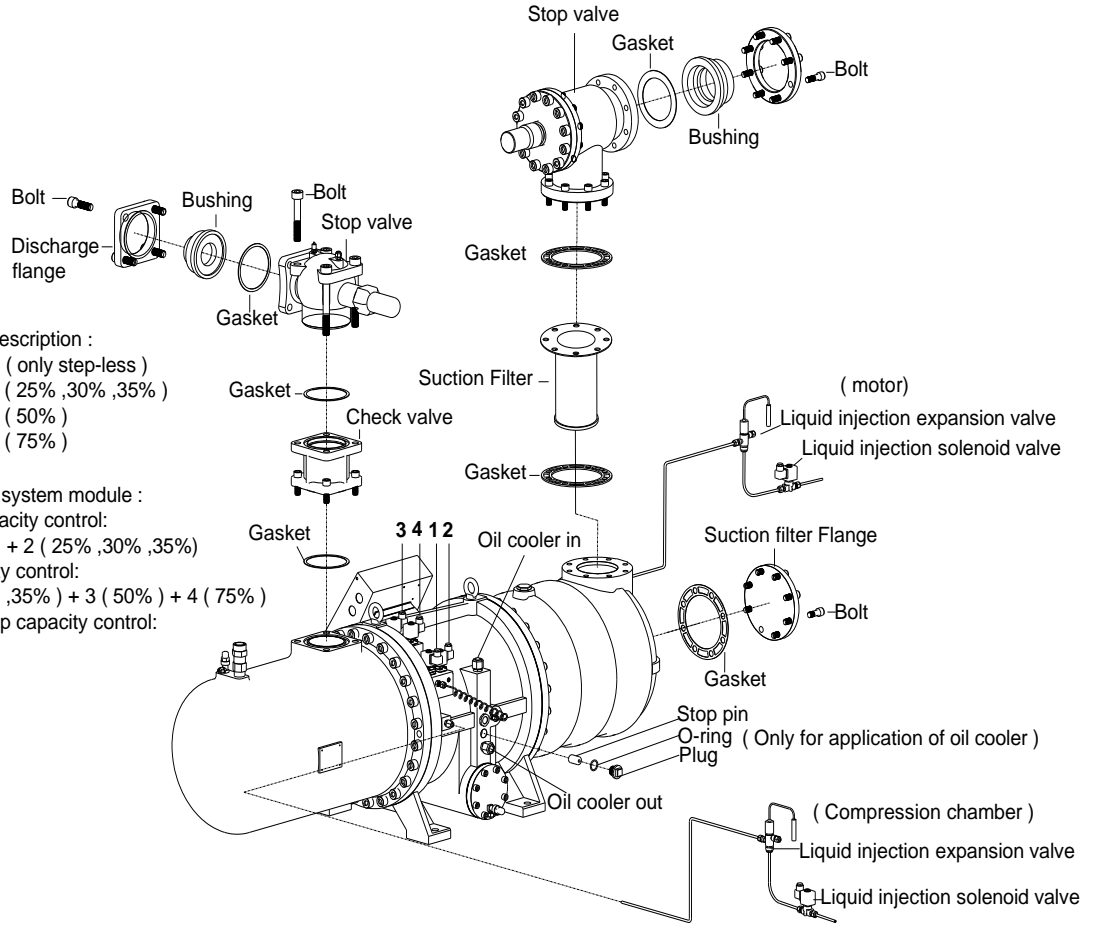

d. RC2-1020, RC2-1130, RC2-1270, RC2-1530

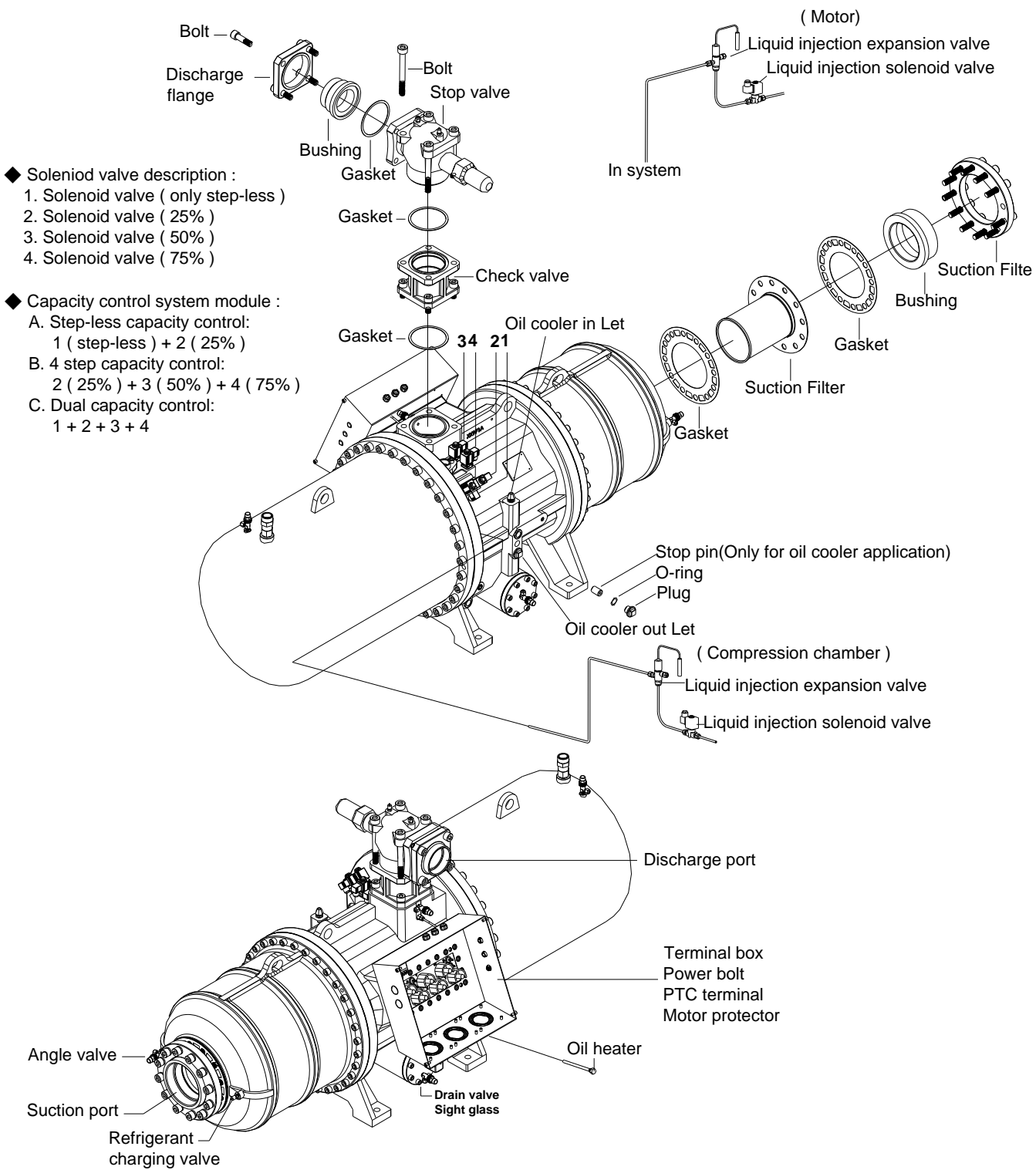



5. Electrical data and design

5.1 Motor design

HANBELL RC2 series screw compressors are fitted with Y-Δ motor as standard. But Δ/Δ motor (Part Winding Starting – PWS) is also available for model RC2-100A ~ RC2-580A & RC2-100B ~ RC2-580B.

i.e. ●RC2-100A ~ RC2-580A & RC2-100B ~ RC2-580B both Y-Δ motor and Δ/Δ motor are available.

●RC2-620A ~ RC2-1530A & RC2-620B ~ RC2-1530B only Y-Δ motor are available.

Y-Δ Starting

Y-Δ motor connects motor coil by Y connection during starting therefore reducing voltage on coils to $1/\sqrt{3}$ of input voltage and reconnects motor coil by Δ connection after starting. By doing so, we can decrease starting current through voltage drop, i.e., so-called voltage-drop starting.

Y-Δ motor connection method is shown in the following motor wiring diagram:

In Y connection, MCM, MCS are inductive while motor leads Z,X,Y are tied together as a neutral connecting as Y fashion. A few seconds later (3~5 sec is recommended), MCM, MCS become deductive. Around 0.25 sec later, MCM,MCD are inductive, it turns out Δ run connection.

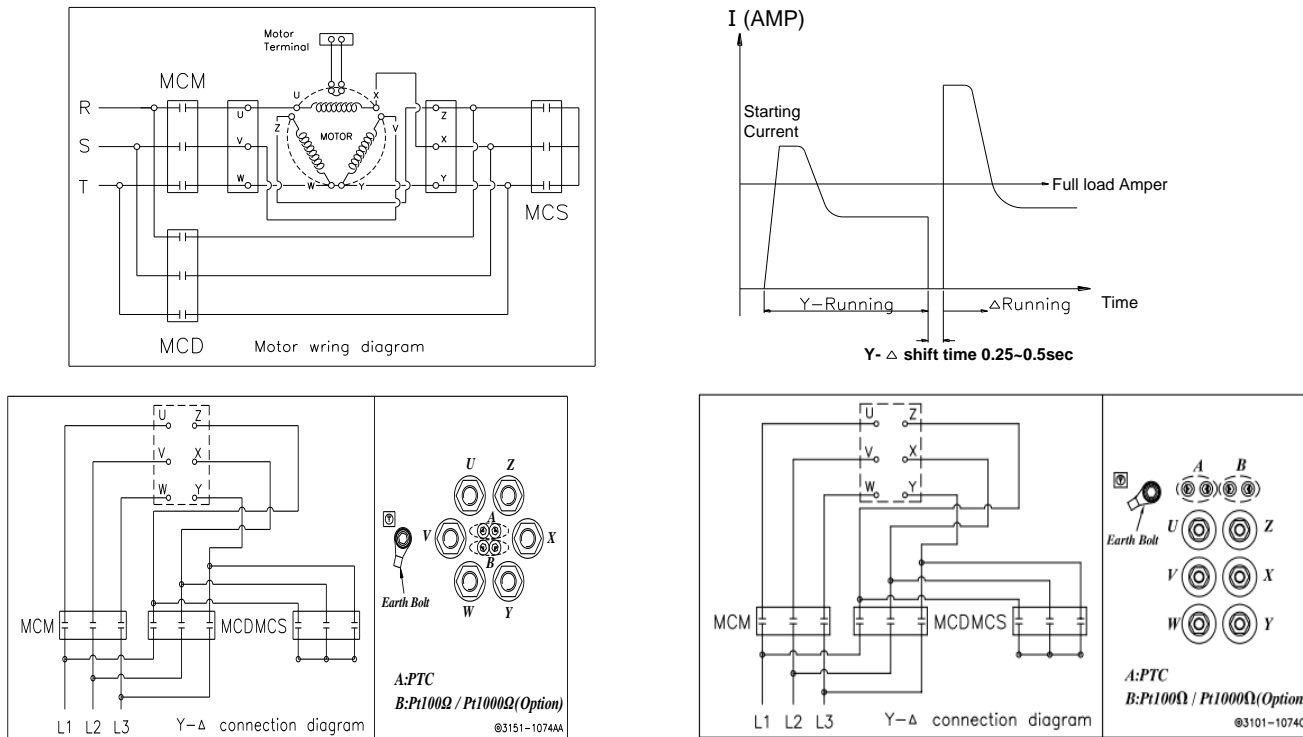

Figure 54 Y-Δ Starting diagram

Attention! : After Y start, MCM & MCS are deductive for 0.25 sec and then MCM & MCD are inductive for Δ run. Within as transient as 0.25 sec, pseudo short circuit might occur due to inappropriate action of contactors, causing trip of compressors. When it occurs, we recommend usage of adjustable Y-Δ dedicated timer or slightly lengthen span of time for MCM, MCS deduction - MCM, MCD re-induction from 0.25 sec to 0.5 sec max directly in micro controller or PLC program. Please refer to Y-Δ shift time diagram for details. Because motor is not powered during Y-Δ shift, shorter Y-Δ shift span is suggested to prevent second start due to decreased rotation speed. However, if Y-Δ shift span is too short, aforementioned pseudo short circuit might occur.

Characteristics of Y-Δ Starting

1. Starting current in Y connection is $1/3$ of lock rotor ampere.
2. Starting torque in Y connection is $1/3$ of lock rotor torque.
3. Acceleration of motor rotor becomes smaller at full-load starting, therefore compressors require starting at partial load.

Δ/ΔΔ (PW) starting

RC2-100A ~ RC2-580A & RC2-100B ~ RC2-580B are available to be fitted with PWS motor for customer's application as an optional accessory. Please refer to the follow diagram for the wiring of PWS motor.

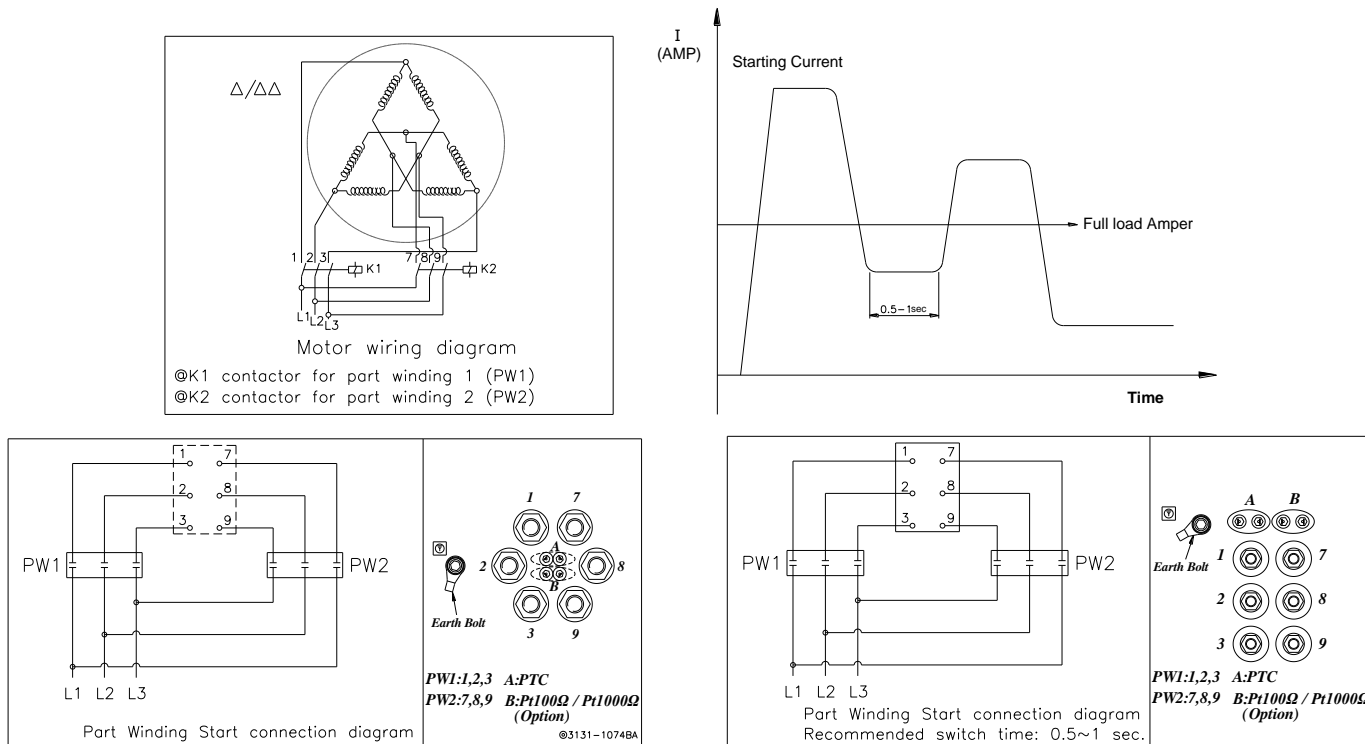

Figure 55 Δ/ΔΔ (PW) starting diagram

The selection of both of the motor contactors (k1 / k2) is each for approx. 60% of the max. running current. The recommended time delay of the switching relay k1 is to be set at 0.5 second and not more than 1 second.

PWS Starting features

The starting current is around 40% ~ 70% of full-winding Locked Rotor Current. It depends on the design and motor size, and low starting torque.

Direct on line features

The starting equipment consists of only a main contactor and thermal or electronic overload relay. During a direct-on-line start, the starting torque is very high, and is higher than necessary for most applications. The disadvantage with this method is that it gives the highest possible starting current. Please refer to the follow diagram for the wiring of DOL starting

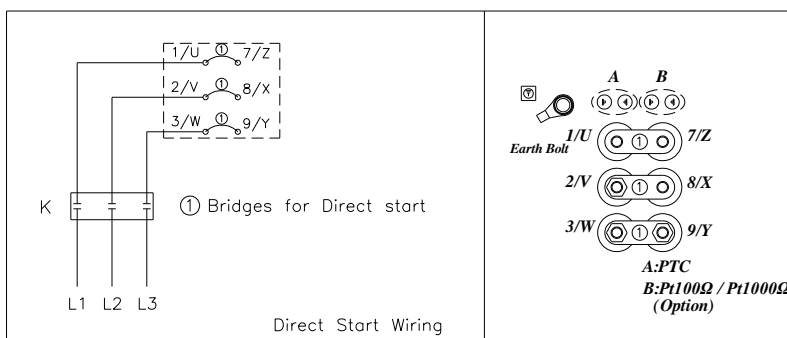

Figure 56 DOL starting diagram

Soft starting features

A soft starter is different from other starting methods in characteristics. It has thyristors in the main circuit, and the motor voltage is regulated with a printed circuit board. The soft starter's advantage is that when the motor voltage is low during start, the starting current and starting torque is also low. Please refer to the following diagram for wiring of soft starting.

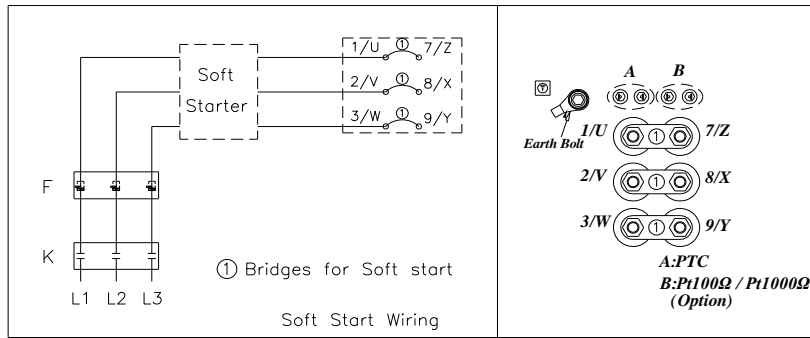

Figure 57 Soft starting diagram

Besides Y-Δ and PWS start, if there were any inquiry of direct on line start · soft start · inverter start or series reactance reduced voltage start, please contact Hanbell for further information.

Power supply wiring application (RC2-1270 and 1530 only)

To assure that power supply wiring to starter panel is properly installed and connected, please review and follow the guidelines:

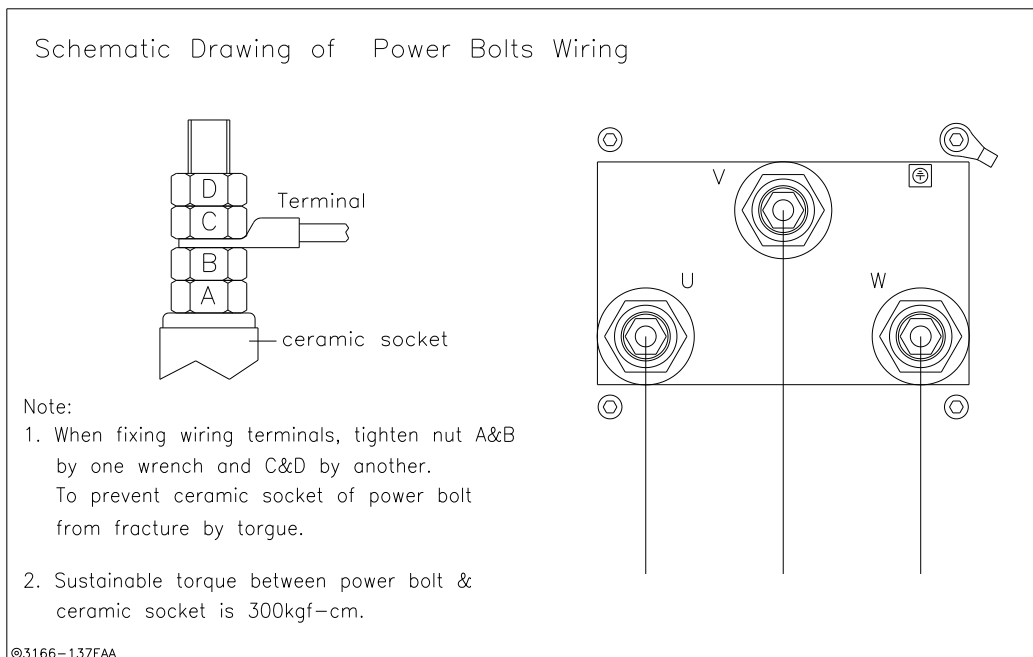

Figure 26: Power bolt connection

- a. Power source application
 - (1) Verify that nameplate ratings are compatible with the power supply of the system.
 - (2) Use copper conductors to connect the power supply.
 - (3) Size the power supply wiring of the compressor: maximum current in required operating condition x 1.25 (25% safety factor).
 - (4) Make sure that incoming power wiring is properly phased; each power supply conduit connects to each conductor in correct sequence to ensure equal phase representation as number 1-2-3 in order.
 - (5) Use flexible conduit to enhance serviceability and minimize transmission of vibration.
 - (6) Size the circuit breaker or fuse according to NEC or local guidelines.
 - (7) As install the power supply conduit, make sure that its position does not interfere with any compressor components, or with other equipments.
- b. Accessories for connection between the starter and the motor
 - (1) Grounding wire terminal lugs are provided inside the motor terminal box.
 - (2) Terminal clamps are supplied with motor terminals to accommodate standard motor wire terminal lugs.
- c. Wire terminal lugs
 - (1) Use adequate size wire terminal lugs for the application.
 - (2) Carefully choose the size of wire lugs for compatibility with the conductor sizes specified by the electrical engineer
 - (3) Use copper washers on power bolt connections.
 - (4) Tighten each bolt to 300kgf-cm
 - (5) These connections should be completed under supervision of a qualified engineer in compliance with NEC or local guidelines

Caution: Ensure the power supply wiring and output motor wiring are connected to the correct terminals. Any mistake could cause catastrophic failure to compressor motor.

5.2 Compressor protection devices

The table below shows the list of protection devices which are essential to protect the compressor and operate safely. Follow the protection devices listed in the below table to ensure the compressor running under normal condition.

Protection device	Set point	Remark
Motor wiring temperature protector (PTC sensor)	Cutout 110°C, cut in 100°C ※	Standard
Discharge temperature protector (PTC sensor)	Cutout 110°C, cut in 100°C ※	Standard
Phase reversal protector (INT69HBY)		Standard
Phase failure protector (INT69HBY)		Standard
Oil temperature sensor	Cutout 100°C, cut in 90°C (Air-cooled, heat pump, or refrigeration system) Cutout 80°C, cut in 70°C (Water-cooled or flooded system)	Optional
Oil level switch	Time delay setting: 10~15 seconds	Optional
Oil filter pressure differential switch	Cutout 1.5 kg/cm ² g	Optional
Oil pressure differential switch	Oil inlet pressure should be 4 kg/cm ² g higher than the suction pressure. When it is not 4kg/cm ² g higher than the suction pressure, it is necessary to add a minimum pressure valve or an oil pump to ensure proper oil supply	Optional
Oil flow switch	Time delay setting: 10~15 seconds	Optional
Pt100 or Pt1000 for liquid injection to motor chamber.	Depends on customer's application. Suggest Cut in 60°C, cut out 50°C	Optional

※Manual reset suggested

Motor thermistors and discharge thermistors are temperature sensors with quick response while the temperature approach to their set point; thermistors must be connected in series to a controller (INT69HBY) in terminal box as a guardian to protect compressor. Alarm lamp for this protector is required to be embedded on control panel as indicator. Any intention to short controllers for starting of compressors is prohibited. It is beyond Hanbell's warranty of compressors if there is any action above mentioned found.

Note: when any protection device trips, please do troubleshooting and reset manually. Do not let the compressor reset automatically after abnormal trip!

5.3 Power supply

1. Limitation of power supply

a. Voltage limitation

Long-term running: rated voltage $\pm 5\%$

Instant running: rated voltage $\pm 10\%$

b. Frequency :

Rated frequency $\pm 2\%$

Note: In the region where the electricity power is unstable, install an additional hi-low voltage protector with $\pm 5\%$ tolerance of normal voltage to ensure safe operating of the compressor.

2. Unbalanced voltages :

Unbalanced voltages usually occur because of variations in the load. When the load on one or more of the phases are different from the other(s), unbalanced voltages will appear. This can be due to different impedances, or type and value of loading in each phase. Unbalanced voltages can cause serious problems, particularly to the motor.

NEMA defines voltage unbalance as follows:

$$\text{Percent voltage unbalance} = 100 \times \frac{(\text{maximum voltage deviation from average voltage})}{(\text{average voltage})}$$

NEMA states that poly-phase motors shall operate successfully under running conditions at rated load when voltage unbalance at the motor terminals does not exceed 1%. Furthermore, operation of a motor with over 5% unbalance is not recommended for it probably results in motor damage.

Unbalanced voltages at motor terminals cause phase current unbalance ranging from 6 to 10 times the percent of voltage unbalance for a fully loaded motor. This causes motor over current resulting in excessive heat that shortens motor life, and hence, eventual motor burnout. If the voltage unbalance is great enough, the reduced torque capability might not be adequate for the application and the motor will not attain rated speed.

Some of the more common causes of unbalance voltages are :

- Unbalanced incoming utility supply
- Open delta connected transformer banks
- Large single phase distribution transformer in the system
- Open phase on the primary 3-phase transformer in the distribution system
- Blow fuse on 3 phase bank of power factor improvement capacitors
- Unequal impedance in conductors of power supply wiring
- Unbalanced distribution of single phase loads such as lighting
- Unequal transformer tap settings
- Faults or grounds in power transformer



- Heavy reactive single phase loads such as welders

A 3-phase unbalanced voltages protector is upon request as optional accessory. Please contact Hanbell for more details.

5.4 Grounding

There's a grounding terminal inside cable box. Please accurately connect it to grounding of control panel for the system.

Suggestion:

- The regular setting of electric leak protection should be greater than 50mA; for a humid location, 25mA is better.
- Grounding voltage of casing should be no greater than 50V; for a humid location, the limit is 25V.
- Grounding resistance should be no greater than 500 Ohm.
- Air cut board (ACB) is regularly equipped with electric leak protection. Please refer to related settings for its normal action.
- If electric leak protection is active, please check if insulation of equipments is normal and if its wiring and setting are correct.

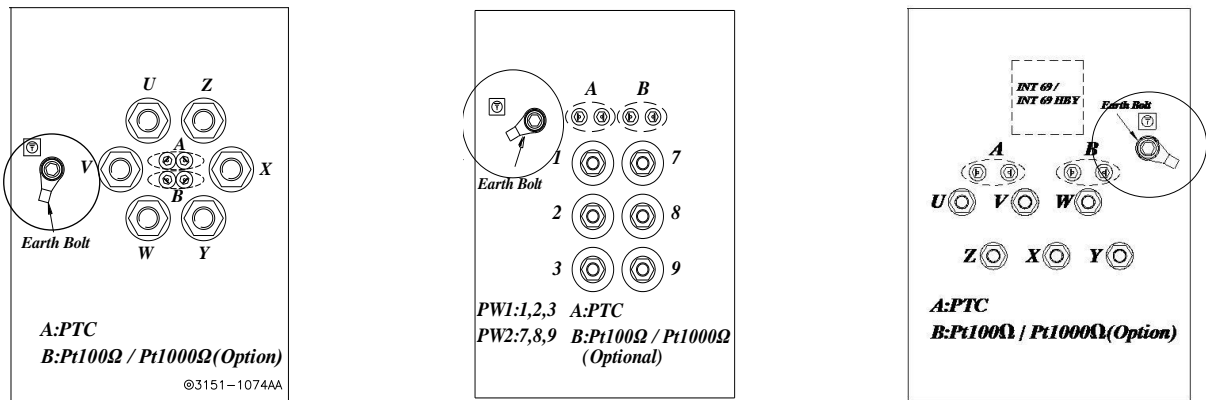

Figure 58 Grounding Terminal

Please make sure nothing is wrong before turning on the power. If there are any questions, please contact the supplier of equipments.

5.5 Torque Value for power bolts

Torque Value for power bolts		
Model	Bolt size	Torque value (kgf.cm)
RC2-100~180	M8	200
RC2-140~180	M12	350
RC2-200~830	M12	350
RC2-710~930	M16	500
RC2-1020~1530	M16	500

6. Operation and maintenance

6.1 Compressor start-up

PRE-START CHECKING- Table below shows the required procedures and checkpoints before starting-up the compressor during commissioning or initial operation of the unit.

Items	Things to be checked	States or standard values
1. Accessories	<ol style="list-style-type: none"> 1. Oil level 2. Oil heater 3. System valves status 4. Solenoid valves 5. Capillary 	<ol style="list-style-type: none"> 1. Higher than the middle line of oil level sight glass 2. Should be kept energizing after compressor shut down. 3. Opened 4. Fixed 5. No serious distortion or damaged
2. Electrical system	<ol style="list-style-type: none"> 1. Voltage of main power 2. Voltage of control circuit 3. Insulation resistance value of the motor between phase to phase and phase to ground. 4. Power terminals and wire cables' terminals connection. 5. Grounded 6. Capacity of electrical accessories 7. Settings of switches, sensors and controllers. 	<ol style="list-style-type: none"> 1. Electricity voltage should be kept within 5% to the rated voltage, instant maximum voltage drop while starting should be less than 10% to the rated voltage. 2. Standard voltage is 220V. Maximum voltage is 230V. If there is other demand, contact HANBELL. 3. Insulation resistance value should be above 5MΩ. 4. Power terminals are firmly fixed on terminal block and well insulated. Keep wire cables away from heat source and sharpened metal. Power terminals are fixed firmly and well insulated. Terminal screw and block are both required. 5. (Ruled by the local Electricity Regulations.) 6. Properly selected (or inquired by the system designer.) 7. Properly set (or inquired by the system designer.)
3. Piping system	<ol style="list-style-type: none"> 1. Outer piping system 2. Leakage test 3. Bolts to fix the compressor. 	<ol style="list-style-type: none"> 1. Fixed firmly. 2. No leakage. 3. Fix the compressor tightly.
4. Safety devices	<ol style="list-style-type: none"> 1. Motor coil sensor (thermistor) 2. Discharge sensor (thermistor) 3. Controller 	<ol style="list-style-type: none"> 1. Connected in series with discharge sensor to controller. 2. Connected in series with motor sensor to controller. 3. Closed circuit with N.C. & N.O.

In addition to the pre-start checking given in the above table, please also consider the following:

- It is necessary to pay more attention to the auxiliary facilities while the chiller is commissioning at the job-site and the periodic maintenance after the initial start-up.
- For a new chiller with compressor put in stock for a long time, it is recommended to add 1 to 1.5 liter of oil in the motor casing to provide better screw rotor lubrication during compressor's initial start-up.
- In order to keep the capacity control smoothly under the low ambient temperature with the normal viscosity of oil, oil heater should be kept energizing after compressor has been shut down for preparation for the next start-up.
- Check that all the settings on each pressure switch are correct.
- Check if all the stop valves in the system are already open.
- Check the rotating direction of the compressor by starting the compressor for a split second (approx. 0.5...1 sec.) and check the suction and discharge pressure gauges. The correct rotating direction is: suction pressure drops immediately and the discharge pressure will go up.
- Compressor's lubrication oil should be checked immediately after starting. Oil level should be within sight glass range or higher than the middle line of oil level sight glass.
- Oil foaming can be generated during starting phase, but it should reduce when the compressor is under stable operating conditions. Otherwise this can indicate excessive liquid in the suction gas.
- The running condition of compressor after commissioning at the job-site should be adjusted as; the discharge temperature will be at least 20K above the saturated condensing temperature and the suction vapor superheat should be within 10K to the saturated evaporating temperature.
- The whole plant, especially the pipelines and capillary tubes must be checked for abnormal vibrations. Please contact HANBELL or local distributor if any abnormal vibrations or noise found while compressor is running.
- Regularly check the plant according to national regulations and the following items should also be checked:
 - Operating data of the machine
 - Check the lubrication/ oil level
 - All compressor protection devices
 - Check electrical cable connections and tightness



6.2 Troubleshooting

The table below shows some problem that might encounter in the jobsite during commissioning or upon operation of compressor. This table will only serve as a guide for the Engineer to understand the situation once the problem occurred in the site.

PROBLEMS	PROBABILITY CAUSES	REMEDY / CORRECTIVE ACTION	
Sudden trip of motor thermistor / sensor	Low suction pressure cause low refrigerant flow rate	Install liquid injection to motor coil	
	Refrigerant shortage	Charge refrigerant	
	Suction filter clogged	Clean filter	
	High suction temperature	Install liquid injection to motor coil	
	High suction superheat	Adjust the superheat less than 10°K	
	Unstable electricity system or failure	Check electricity power supply	
	Motor overload		
	Bad motor coil causing temperature rising rapidly		
Compressor unable to load	Low ambient temperature or high oil viscosity.	Turn on the oil heater before compressor start.	
	Capillary clogged.	Clean or replace capillary	
	Modulation solenoid valve clogged or solenoid valve coil burnt.	Clean / purge solenoid valve core or replace the solenoid valve coil	
	Internal built-in oil line clogged.	Check and clean the compressor oil circuit	
	Piston stuck-up.	Change piston or piston ring	
	Oil filter cartridge clogged.	Clean oil filter (replace if needed)	
	Too small the high-low pressure differential.	Minimum pressure differential is 4 bar. Consider to install an oil pump.	
	Modulation solenoid valve clogged or burnt.	Clean or replace the solenoid valve	
Compressor unable to unload.	Piston rings worn off or broken, or cylinder damaged resulting leakage.	Change piston (if cylinder damaged severely, change the cylinder)	
	Lubrication oil insufficient.	Check the oil level of the compressor if enough, add some oil if necessary	
	Leakages at internal discharge cover plate end side.	Check or replace the gasket and tighten the bolts.	
	Solenoid valve voltage misused.	Check the control voltage	
	Piston stuck-up.	Change the piston set, and check the cylinder and slide valve.	
	Capacity control logic unsuitable.	Check	
	Poor insulation of motor	1. Bad compressor motor coil.	Check the coil or change the motor stator
		2. Motor power terminal or bolt wet or frosty.	
3. Motor power terminal or bolt bad or dusty.			
4. Bad insulation of magnetic contactors.			
5. Acidified internal refrigeration system.			
6. Motor coil running long time continuously under high temperature.			
7. Compressor restart counts too many times.			
Compressor starting failure or Y-Δ starter shifting failure	Slide valve piston unable to go back to its lowest % original position.	Check if the unloading SV is energized once the compressor shut down. Unload the compressor before shot down.	
	Voltage incorrect.	Check the power supply	
	Voltage drop too big when starting the compressor or magnetic contactor failure or phase failure.	Check the power supply and the contactor.	
	Motor broken down	Change the motor	
	Motor thermister sensor trip.	See "sudden trip of motor sensor" above	
	Incorrect supply power connection.	Check and re-connect	
	Y-Δ timer failure.	Check or replace.	
	Discharge or suction stop valve closed.	Open the stop valve	
	Improper connection between node terminals of Y-Δ wiring.	Check and re-connect the wiring	
	Rotor locked	Check and repair	
	Earth fault	Check and repair	
Abnormal vibration and noise of compressor	Protection device trip	Check	
	Damaged bearings.	Change bearing.	
	Phenomenon of liquid compression.	Adjust proper suction superheat	
	Friction between rotors or between rotor and compression chamber.	Change screw rotors or/and compression chamber.	
	Insufficient lubrication oil.	Check the oil level of the compressor if enough, add some oil if necessary.	
	Loosen internal parts.	Dismantle the compressor and change the damaged parts.	
	Electromagnetic sound of the solenoid valve.	Check	
	System harmonic vibration caused by improper piping system.	Check the system piping and if possible improve it using copper pipe.	
Compressor does not run	External debris fallen into the compressor.	Dismantle the compressor and check the extent of the damage.	
	Friction between slide valve and rotors.	Dismantle the compressor and change the damaged parts.	
	Motor rotor rotates imbalance.	Check and repair.	
	Motor line open	Check	
	Tripped overload	Check the electrical connection	
	Screw rotors seized	Replace screw rotors, bearings etc....	
	Motor broken	Change motor.	
	High discharge temperature	Insufficient refrigerant.	Check for leaks. Charge additional refrigerant and adjust suction superheat less than 10°K
		Condenser problem of bad heat exchange.	Check and clean condenser
		Refrigerant overcharge.	Reduce the refrigerant charge
Air / moisture in the refrigerant system		Recover and purify refrigerant and vacuum system	
Improper expansion valve.		Check and adjust proper suction super heat	
Insufficient lubrication oil.		Check the oil level and add oil.	
Damaged bearings.		Stop the compressor and change the bearings and other damaged parts.	
Improper Vi value.		Change the slide valve.	
Compressor losses oil	No system additional cooling (Liquid injection or oil cooler)	Install additional system cooling (liquid injection or oil cooling or both base on working condition limitation)	
	Lack of refrigerant	Check for leaks. Charge additional refrigerant.	
	Improper system piping	Check and correct the piping or install an external oil separator	
	Liquid fills back	Maintain suitable suction superheat at compressor	
Low suction pressure	Lack of refrigerant	Check for leaks. Charge additional refrigerant.	
	Evaporator dirty or iced	Defrost or clean coil	
	Clogged liquid line filter drier	Replace the cartridge	
	Clogged suction line or compressor suction strainer	Clean or change suction strainer	
	Expansion valve malfunctioning	Check and reset for proper superheat	
	Condensing temperature too low	Check means for regulating condensing temperature	

Note: The replacement of compressor internal parts should be perform only by a qualified / certified service technician with full knowledge of HANBELL screw compressor or it should be a Service Engineer from HANBELL.



6.3 Compressor checking list

Please fill out the compressor checking list and send it to Hanbell, if any failure of compressor happened. Hanbell will reply and suggest the solution to resolve the failure.

CHECK LIST FOR TROUBLESHOOTING OF HANBELL SCREW COMPRESSOR

Compressor model : _____ Compressor S/N : _____
 System design condition SCT/SST : _____ Evaporator type : _____
 Refrigerant type : _____ Liquid injection : Motor Chamber
 Voltage : R-S: _____ S-T: _____ R-T: _____ Over load setting : _____ A
 Y-Δ setting: _____ Sec Δ-Δ setting : _____ Sec
 Starting current : _____ A Δ current : _____ A (end of starting)
 Operating current (full load) : R: _____ S: _____ T: _____

- Description of problem :
- A : abnormal noise dBA at % capacity
 - B : abnormal vibration
 - C : over current
 - D : motor burnout
 - E : unable to load
 - F : unable to unload
 - G : leakage (Photo would be a plus)
 - H : accessory parts damaged (Photo would be a plus)
 - I : other (Detail would be a plus)

Suction pressure	Discharge pressure	Suction temp.	Discharge temp.	Liquid line temp.	Condenser water temp.		Chiller water temp.		Oil cooler temp.		Economizer temp.	
					inlet	outlet	inlet	outlet	inlet	outlet	inlet	outlet

E-mail: sales@hanbell.com & service@hanbell.com
 Fax: +886-3-4836223 Tel: +886-3-4836215



7. Applications

7.1 Additional cooling

When compressors operate in the following application conditions, installation of an additional auxiliary cooling apparatus is recommended to lower discharge temperature, maintain proper temperature of lubricant and additional cooling for motor coil... to ensure safe running of compressors with efficiency.

- Air-cooled system
- High compression ratio system such as heat pump, low temperature and refrigeration system
- High discharge temperature system such as heat recovery system
- If compressors have to run at partial load below 50% continuously in a long term.
- Any other heavy duty application

There are two type of additional cooling of compressor that described separately as below.

a. Liquid injection applications

In areas with high condensing temperature and/or low evaporating temperature as in the limitation diagram, additional cooling is required in order for the compressor to work properly. A relatively simple method of additional cooling is direct refrigerant injection in the compressor either in the motor side or compression chamber side.

The purpose of installing a liquid injection system is to prevent the compressor from overheat. The system installed a liquid injection expansion valve between the liquid line and compressor for cooling down the compression chamber and motor to ensure the continuous and safe running of the compressor. The suction superheat should be controlled between 5K~10K for the application of air-cooled and heat pump chillers by means of expansion valve devices. These devices can be adjusted by the stem of the expansion valve to control the suction superheat by means of refrigerant flow rate. When the initial startup, the loading of the chiller is heavy due to the high temperature of chilled water, so the liquid injection devices capacity should be selected or calculated enough to reduce the overheat of the compressor.

Calculating the cooling capacity of liquid injection devices

Liquid injection devices can be calculated with the **HANBELL selection software** or manually. For manual calculation, consider the most extreme conditions to be expected during actual operations i.e. minimum evaporating temperature, maximum suction gas super heat and condensing temperature.

Liquid injection applied with low temperature expansion valve

When the compressor applied in the low temperature system ($E.T. \leq -10^{\circ}C$) the compression ratio is high at this condition, also the discharge temperature will be very high. The design of the liquid injection system for low temperature application is similar to the illustration shown in figure below. There are two connectors for the liquid injection in the compressor, one is in the motor side to cool down the motor temperature and reduce the discharge temperature. The other is in the compression chamber side and its function is to reduce the discharge temperature and increase the compression efficiency. However, when additional cooling in compression chamber like economizer operation, oil cooler application is used or when condensing temperature is low, discharge temperature will be kept low and liquid injection may not be turned on, although motor load is severe and motor coil temperature is high. This may lead to motor failure. Therefore, in application mentioned above Pt100 or Pt1000 for liquid injection to motor is recommended instead.

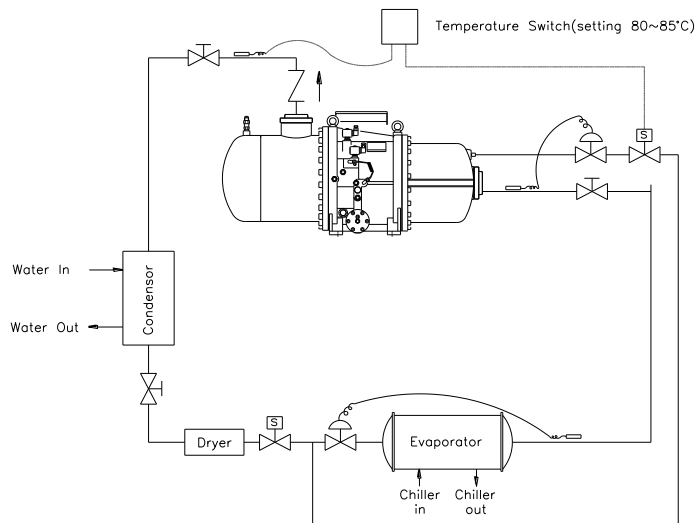

Figure 59 Liquid injection connected to motor

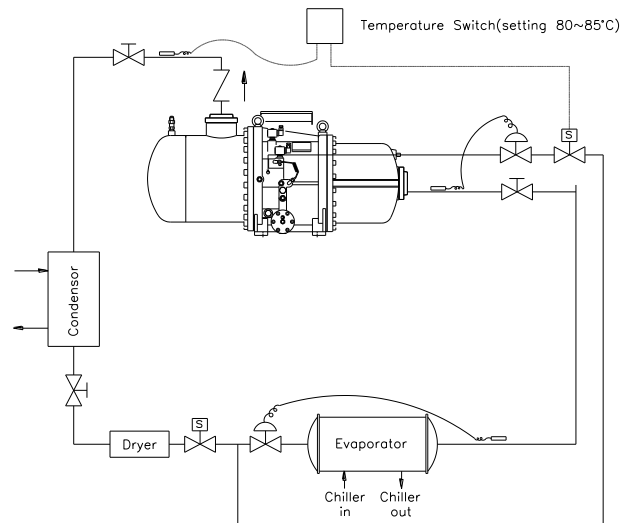

Figure 60 Liquid injection connected to compression chamber

Liquid injection applied with high temperature expansion valve

Select the high temperature expansion valve, which can sense the discharge temperature with its remote bulb. This can control the opening of expansion valve proportionally, and can reach the best cooling effect; it will control the compressor discharge temperature at an optimal situation of around 80°C.

It can also be installed with an additional solenoid valve or service valve in front of the high temperature expansion valve for the maintenance purposes. The solenoid valve will be opened while starting the compressor. The equilibrium tube of high temperature expansion valve should be connected to the high-pressure side to counter the internal pressure.

However, when additional cooling in compression chamber like economizer operation, oil cooler application is used, or when condensing temperature is low, discharge temperature may be kept low and liquid injection may not be turned on, although motor load is severe and motor coil temperature is high. This may lead to motor failure. Therefore, in applications mentioned above, Pt100 or Pt1000 for liquid injection to motor is recommended instead.

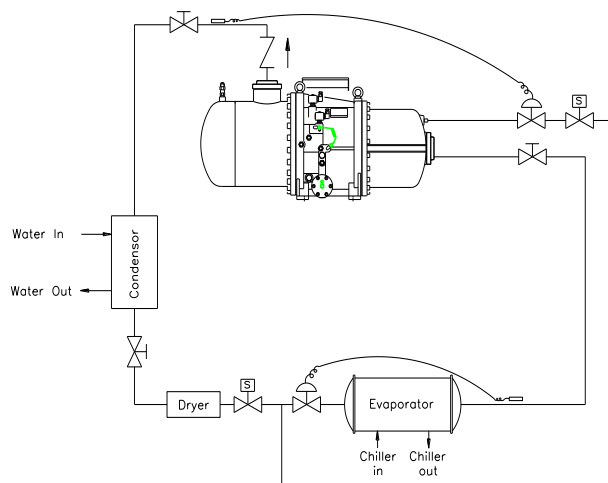

Figure 61 Liquid injection (high temperature type) connected to motor

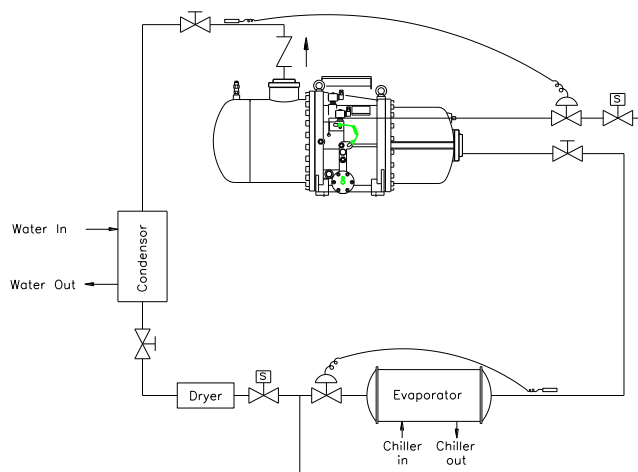

Figure 62 Liquid injection (high temperature type) to compression chamber

b. Oil cooler applications

Compared to liquid injection applications, external oil cooler applications reduces the discharge temperature and at the same time gives better efficiency. Oil cooler application can be classified into 3 types: cooling by refrigerant, cooling by ambient air, cooling by cooling water. Oil cooler capacity can be calculated manually or using HANBELL selection software. When calculating manually, worst case operating conditions must be considered: minimum evaporating temperature, maximum suction gas superheat, maximum condensing temperature and the operation mode.

Cooling by refrigerant

The cooler uses refrigerant as the cooling medium. A basic refrigerant-cooled oil cooling system is shown in Figure 63.

In the oil cooler, solenoid valve for refrigerant circuit is controlled by oil temperature of the oil outlet of compressor.

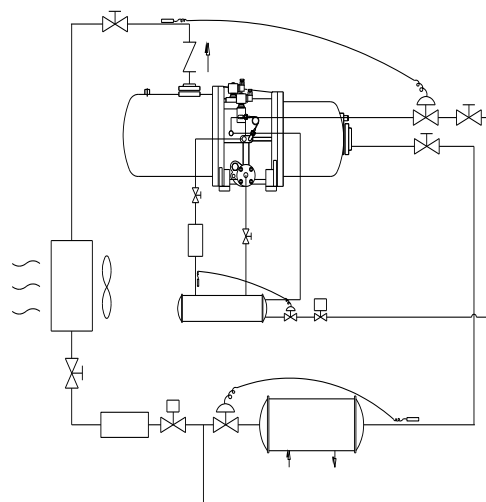

Figure 63 Oil cooling by refrigerant



Air-cooled oil cooling (cooling by ambient air)

The basic air-cooled oil cooling system is shown in Figure 64. This method of cooling is indirect cooling which uses ambient air to cool down the oil, which circulates in the oil cooler.

In the oil cooler, fan is controlled by oil temperature of the oil outlet of compressor.

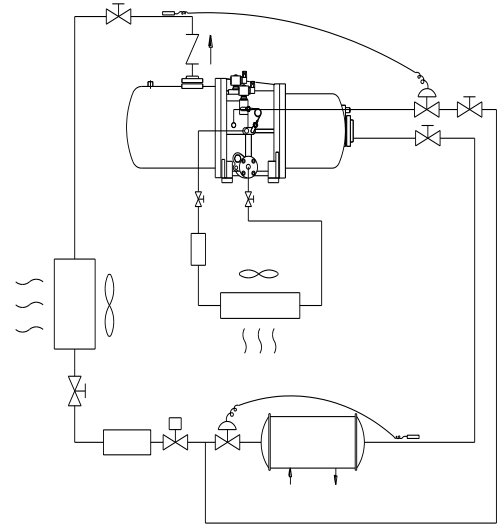

Fig. 64 Oil cooling by

ambient air

Water-cooled oil cooling (cooling by water)

This cooling method utilizes a shell and tube heat exchanger and a source of cooled liquid from an external cooling tower or closed loop evaporative cooler. Once-through water can be used but results in high water usage. An indirect cooling system uses a pump to circulate the cooling medium and a cooling tower or evaporative cooler to reject heat from the cooling medium. The basic water-cooled oil cooling system is shown in Figure 65.

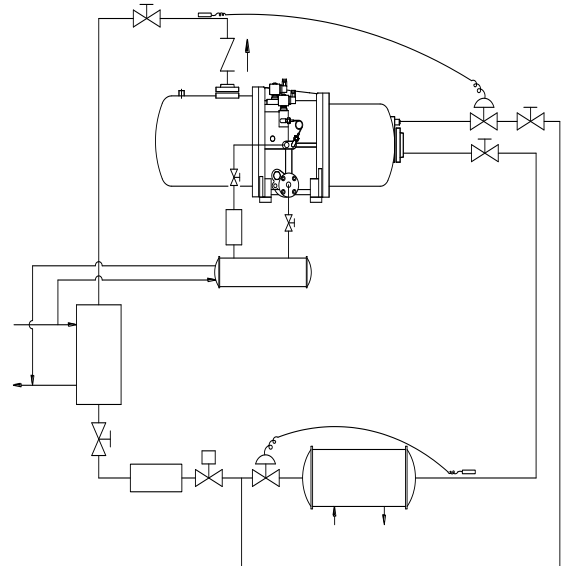

Figure 65 Oil cooling by water

Note:

1. Please decide appropriate oil cooler capacity by referring to HANBELL selection software.
2. The max. pressure drop allowed in external oil cooler is 1.5 kg/cm².
3. When applying an oil cooler with a compressor, please add appropriate refrigeration oil in accordance with the size of oil cooler as well as the length of piping.
4. For RC2-100/140/180, their oil circuit design is different from others. These models don't use the oil stop pin for external oil cooler application. If you find the oil connector (inlet/outlet) installed on the compressor, this means the oil needs to flow out from the oil outlet connector and flow in to the oil inlet connector. If you don't use external additional cooling, you should simply see a cover plate on this position which means the oil will pass this internal tunnel and way up to the cylinder and bearings. Please refer to the illustration below.

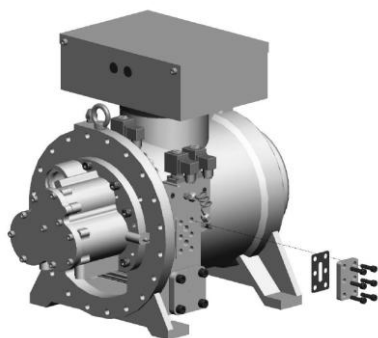

Figure 66 Internal oil circuit application

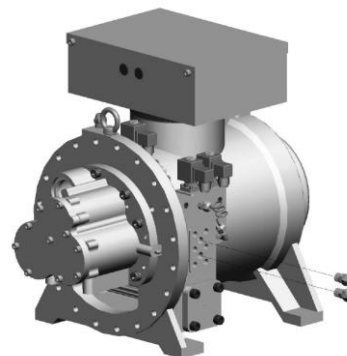

Figure 67 External oil circuit application

7.2 Economizer applications

HANBELL screw compressor can be fitted with an additional middle connection for economizer operation. With this form of operation, refrigeration capacity and also system efficiency can be improved by means of a sub-cooling circuit or two-stage refrigerant expansion.

Based on HANBELL extensive research a special design of the economizer connection has been developed so that the connection causes no additional back flow losses during compression. As a result of this, compressor capacity is fully retained in all operating conditions.

Please refer to Hanbell selection software for calculation of economizer capacity at different operating conditions.

Principle of operation

As opposed to the reciprocating operation of a piston compressor, the compression in a screw compressor takes place only with one flow direction. When the rotors turn, refrigerant vapor is pressed into the rotor grooves by the opposing rotor teeth and transported to end wall of the corresponding working space. In this phase, the volume is steadily reduced and the vapor is compressed from suction pressure to condensing pressure.

The pressure at the additional middle connection is at a similar level to the intermediate pressure with a two-stage system. As a result of these features, a screw compressor of this design can be combined with an additional sub-cooling circuit or an intermediate pressure vessel (flash type sub-cooler) for two-stage expansion. These measures result in a clearly increased refrigeration capacity due to additional liquid sub-cooling, especially with high-pressure ratios. The power consumption of the compressor increases slightly compare to the additional work that takes place at a better level of efficiency.

System with Economizer (sub-cooler)

With this form of operation, a heat exchanger (refrigerant sub-cooler) is used to sub-cooled liquid refrigerant. The sub-cooling is achieved by injecting a part of the refrigerant from the condenser through an expansion device in counter flow into the sub-cooler, which then evaporates due to the absorption of heat. The superheated vapor is pulled into the compressor at the Economizer connection and mixed with the vapor, which is already slightly compressed from the evaporator.

The sub-cooled liquid is at condensing pressure with this form of operation, the pipeline to the evaporator does not therefore require any special features, aside from insulation. The system can be generally applied. Figure 67 shows the system with economizer, **sub-cooler**.

System with economizer (flash type)

The liquid sub-cooling is achieved with this form of operation by reducing the boiling point pressure in an intermediate pressure vessel (**flash type sub-cooler**) arranged between condenser and evaporator. This physical effect leads to the cooling of the liquid down to the boiling point, due to evaporation of part of the liquid. To stabilize the pressure of the vessel, a regulator is used which at the same time controls the quantity of vapor flowing to economizer connection of the compressor.

This form of operation gives the most economical thermodynamic performance due to direct heat exchanging. As the intermediate pressure is reduced to the boiling point temperature this system should only be used with flooded evaporators. Figure 68 shows the system with economizer, **flash type sub-cooler**.

Note:

1. When economizer is used, it is recommended to install a muffler before middle-pressure returned gas port in compression chamber to effectively mitigate pulsation noise in middle pressure as shown in the drawing below.

2. A filter and check valve are also recommended to install before ECO port of compressor.

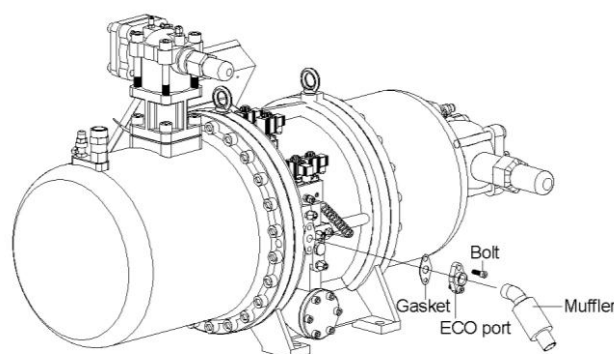

Figure 68 Installation of ECO buffer

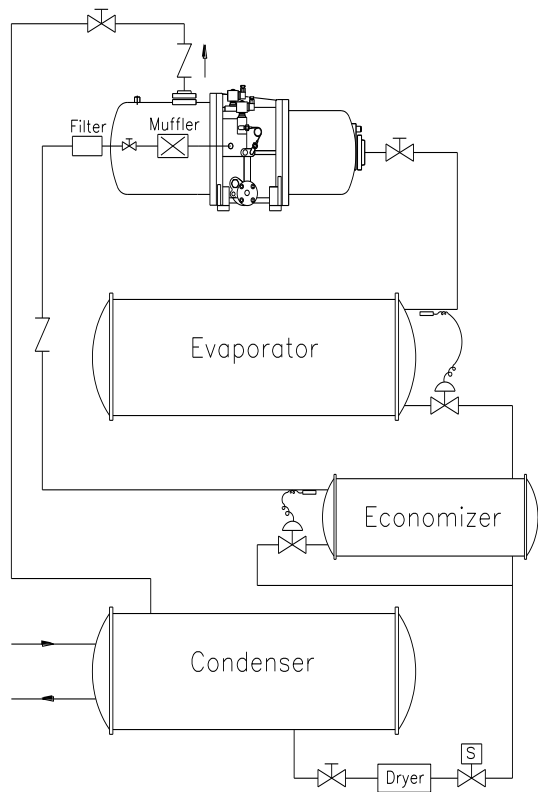

Figure 69 System with economizer (sub-cooler)

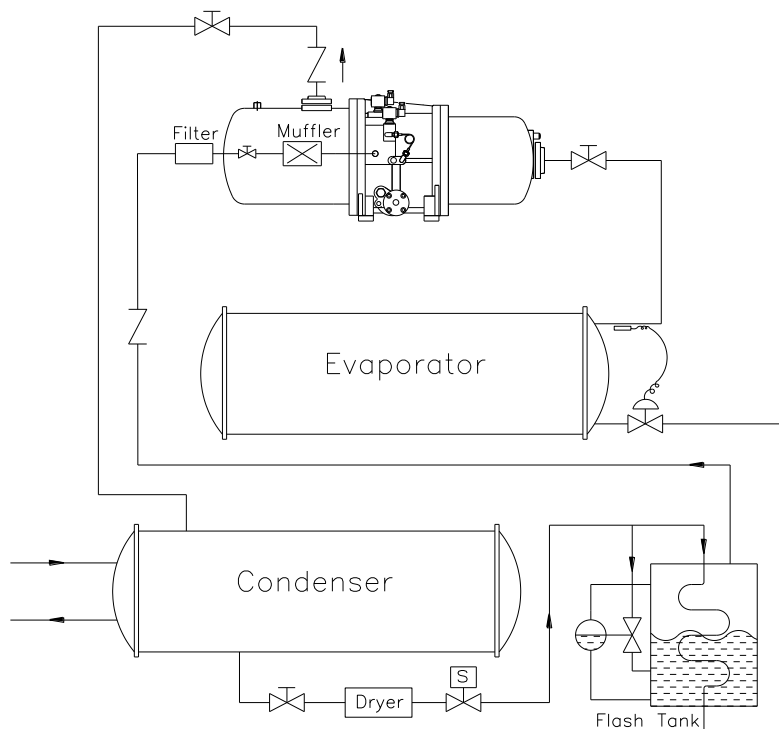

Figure 70 System with economizer (flash type sub-cooler)

7.3 Parallel system applications

In the rack or parallel system, it is possible to happen the unequal-distribution of returned oil from the evaporator that could cause low oil level in one or more of the compressors. Be sure to install the oil level switch inside each compressors and oil flow switch installed in each oil return line to ensure the returned oil in each compressor with normal oil level.

The basic design of the system is shown in Figure 69, twin compressor parallel system connections. The accessories installed are the basic and if there are more applications or protection required, contact HANBELL or local distributor/agent for more information or further confirmation.

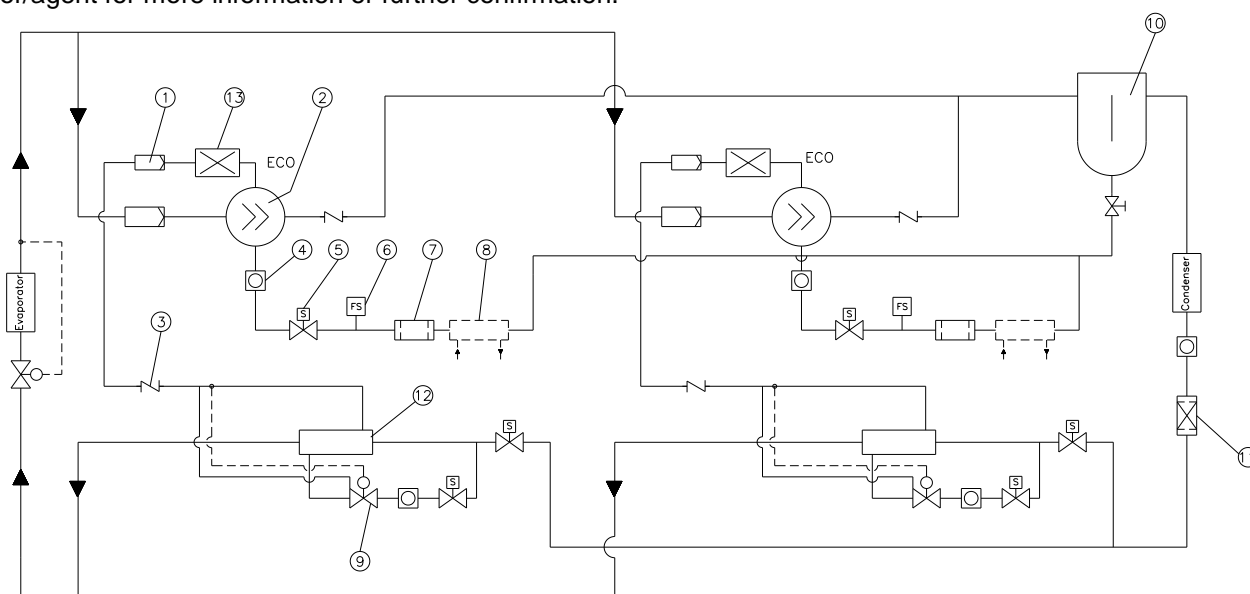

Figure 71 Parallel system with two compressors

Item	Description	Item	Description	Item	Description
1	Filter	6	Flow switch	11	Dryer
2	Compressor	7	Oil filter	12	Secondary cooler
3	Check valve	8	Oil cooler	13	Muffler
4	Sight glass	9	Expansion valve		
5	Solenoid valve	10	Oil separator		

7.4 Oil pump application

An additional oil pump is recommended to install to the system when the differential pressure of oil pressure and suction pressure is less than 4bar (for example: water cooled flooder chiller). If compressor is operating at the mentioned condition, the failure of modulation and lubrication will be happened and will seriously damage the compressor. Besides the installation of additional oil pump, a high – low pressure differential switch is also recommended to install to this kind of system. Please contact with Hanbell for more detailed information of oil pump.

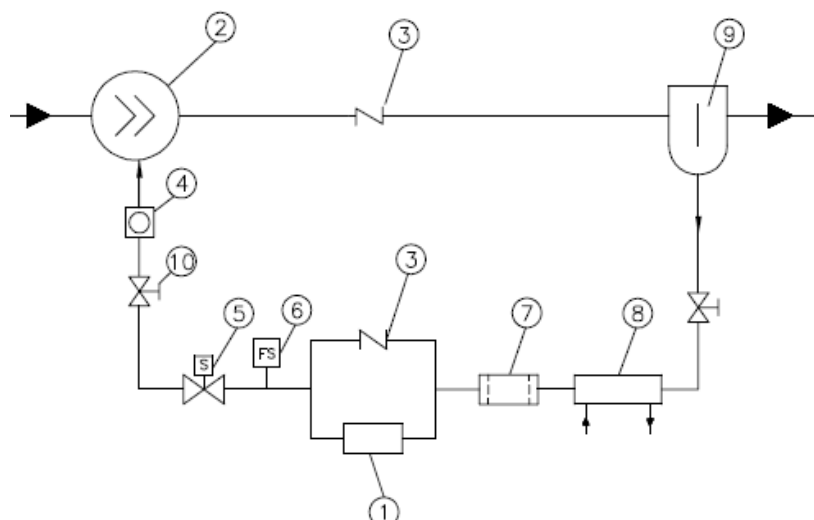

Figure 72 Additional oil pump

Item	Description	Item	Description	Item	Description
1	Oil pump	5	Solenoid valve	9	External oil separator
2	Compressor	6	Flow switch	10	Service valve
3	Check valve	7	Oil filter cartridge		
4	Sight glass	8	Oil cooler		

7.5 Important note of applications of compressor

1. Pump down

Do not pump down the compressor on the chiller as a routine operation except only for temporary maintenance or a long term shut down. Because pump down will cause extremely high temperature in the compression chamber and overheat of the motor as well due to less amount of refrigerant in the suction side. When doing the pump down, be sure to take notice of the items listed below :

- Pump down should be done once each time, as it may be dangerous to the compressor, compression chamber for pumping down repeatedly.
- The minimum suction pressure when doing the pump down should be over 15 psig for R-134a and 25 psig for R22.
- Take notice of compressor running noise. If there is any abnormal noise happened, then emergently stop the pump down.

2. Long term partial load operation

If compressors have to run at partial load below 50% continuously, though maybe within operation limits under such operation condition and with temperature of motor below trip setting for overheating, insufficient dissipation of heat in motor will occur due to lower flow rate of suction gas at partial load. If compressors operate under high temperature for a long time, insulation of motor will deteriorate gradually at risk of serious motor damage finally. In such severe operation conditions, Hanbell strongly recommends installation of liquid injection system to cool motor coil and use of Pt100 or Pt1000 sensor as described in chapter 4.4-s, to effectively control temperature of motor while running. It is suggested to switch on liquid injection when temperature of motor coil is higher than 60°C and turn off liquid injection when it's lower than 50°C.

3. Low pressure receiver

When a compressor operates in the following application conditions, installation of a low pressure receiver is recommended in order to prevent massive liquid refrigerant from returning to the compressor under momentary changes of operation condition.

- Heat pump
- Parallel system
- system with long piping
- operating in the low ambient temperature area
- system heating load varies extremely



8 Selection software

Selection software installation procedure

Step:

1. This compressor model selection software is suitable for the operating system of Windows98, NT or the above edition (Windows ME, 2000, XP, 7, 8, 8.1, 10)
Systematic demand: The magnetic disc space should be at least 300MB.
2. Best resolution of browser please use the whole screen 800x600 degree.
3. Before installing this software, please close all the works and browser windows firstly.
4. To the selection software files, please move the cursor to “**setup.exe**” and double click.
5. And then it will present 「**welcome**」 window, please select “**next**”
Then, 「**users information**」 windows appear, please select “**next**” again and then the windows appear 「**choose the purpose position**」
Finally please choose the file position, click the “**next**” button. (Default recommends)

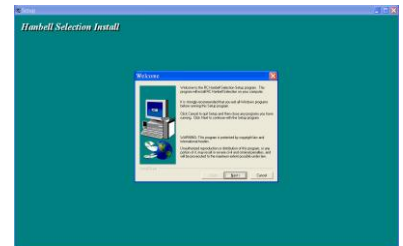

6. The software will decompress automatically.

ESP Operating Procedure:

Step:

1. Before operating our selection software, please check any upgrade of selection software at Hanbell website

2. Enter the main window and it will present products of 「**RC2-A**」, 「**RC2-B**」, 「**RC2-AF**」, 「**RC2-BF**」, 「**RE-A**」, 「**RE-B**」, 「**LB**」, 「**RC2-AV**」, 「**RC2-AVI**」, 「**RG**」, 「**RT**」 button of six series of Hanbell compressors.



3. After selecting 「**RC2-A**」, will present several function buttons:
 - (3.1) choose the unit, 「**SI**」 or 「**Imperial**」. (default unit is **SI**)
 - (3.2) 「**PERFORMANCE**」 button shows the performance sheet of the compressor



The above window is the operating mode of a compressor, just key-in the following condition and then click the 「**Calculate**」 button.

- Refrigerant type
- With economizer (yes/no)
- Compressor model
- Oil cooler or liquid injection
- Power supply (default is 380V 3 50Hz)
- Partial load percent (%)
- Evaporating SST (°C,°F)(default is 0 °C)
- Condensing SCT (°C,°F)(default is 40 °C)

Showed the calculated performance data in the middle of the window.

In the lower part of the window, there are several kinds of buttons:

- 「**Calculate**」 : Must click this key, to calculate the value.
- 「**Tables**」 : Can calculate the coefficient of performance by means of polynomial.
- 「**T.Data**」 : The technical data is the same with function key of technical data
- 「**Print**」 : Copying the calculated performance data
- 「**Vi selection**」 : After calculating, different Vi value can be chose by clicking this button.

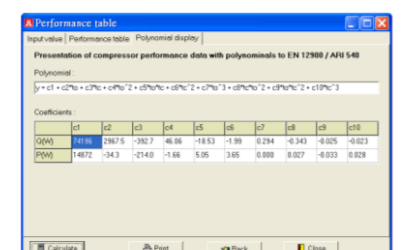

(3.2.1) Click 「**Tables**」 button and the window will appear right one (default window), it can calculate the coefficient of performance using polynomial.

(3.2.2) Click the polynomial display button and then 「**Calculate**」. Presentation of compressor performance data using polynomial calculation.

(3.3) 「**SELECTION**」 by clicking this button, it will help the customer how to choose screw compressor model.

After clicking the 「**SELECTION**」 button, the right window is customer's necessary operating mode. Just key-in the following data.

- Refrigerant type
- Evaporating SST
- Cooling Capacity (KW)
- Condensing SCT
- Power supply

The data shown in the middle of the window is the compressor model and its performance

「**Calculate**」 : Must click this button, to calculate the value. After keying the required data click this button and will show the compressor model and the performance.

「**T.Data**」 : The technical data is the same with function key of technical data(3.4)

「**Print**」 : Copying the calculated performance data

(3.4) 「**T.DATA**」 button is for the detailed technical information that the customer needs to know about the compressor.

(3.5) 「**EXTRA**」 Refrigerant Contrast sheet (Pressure – Temperature) and unit conversion.

Entering the window, it will present the following information:

「**Refrigerant Characteristic**」 (R22, R134a, R407C, R404A)

「**Conversion Tables**」 :

Temperature, length, area, volume, Mass

Pressure, Specific Volume, density, Velocity

Flow rate, power, Specific Enthalpy, Specific Entropy (specific heat)

(3.6) 「**ABOUT**」 Shows the edition of this software and technical support.

(3.7) 「**EXIT**」 Leave current window

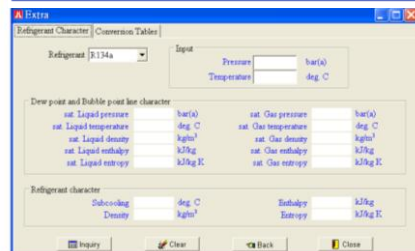
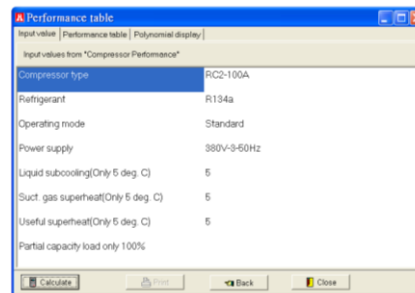
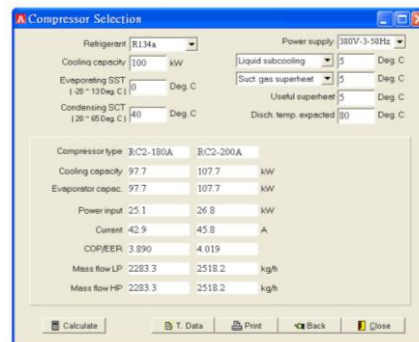



9. Warranty

All HANBELL screw compressors are put through strict quality and performance testing prior to shipping from the factory. The screw compressors are manufactured from the finest quality material and are warranted for one year after the completion of installation and commissioning at the jobsite or up to 18 months from the original date of sales by HANBELL or designated sales agent, whichever comes first.

However, HANBELL will not be responsible if the compressor does not work properly for any of the following reasons:

- 1) damaged caused by others including shipping, natural disaster, war, etc.
- 2) damage caused by improper installation, operation or maintenance that is not in accordance with the HANBELL Technical Manual or instruction,
- 3) damaged caused by modification of any part on or connected to the compressor, and/or
- 4) damage caused by the improper maintenance or repair by a non-authorized technician.
- 5) HANBELL will also not responsible for any accident, which may happen to personnel while installing, setting up, operating, maintaining, and/or repairing the compressor.



Appendix. RC2 Compressor noise level

RC2 Series Screw Compressors' Sound Pressure Level

Hz/Model	RC2-100	RC2-140	RC2-180	RC2-200	RC2-230	RC2-260	RC2-300	RC2-310
50	55.0	55.6	56.5	59.7	60.1	60.4	60.8	61.0
63	51.9	52.4	53.3	56.3	56.7	57.0	57.3	57.6
80	56.9	57.4	58.4	61.7	62.1	62.4	62.8	63.1
100	54.0	54.5	55.5	58.6	59.0	59.3	59.6	59.9
125	53.6	54.1	55.0	58.1	58.5	58.8	59.2	59.4
160	53.1	53.6	54.5	57.6	58.0	58.3	58.6	58.8
200	51.0	51.5	52.4	55.4	55.8	56.0	56.3	56.6
250	60.4	61.0	62.1	65.6	66.1	66.3	66.7	67.0
315	56.1	56.6	57.6	60.9	61.3	61.6	61.9	62.2
400	53.2	53.7	54.7	57.8	58.2	58.4	58.8	59.0
500	57.6	58.2	59.2	62.5	62.9	63.3	63.6	63.9
630	55.5	56.0	57.0	60.2	60.6	60.9	61.3	61.6
800	64.8	65.4	66.6	70.3	70.8	71.1	71.5	71.9
1000	59.8	60.4	61.5	64.9	65.4	65.7	66.1	66.3
1250	66.9	67.5	68.7	72.6	73.1	73.4	73.9	74.2
1600	63.2	63.7	64.9	68.5	69.0	69.3	69.7	70.0
2000	62.0	62.6	63.7	67.3	67.8	68.1	68.5	68.8
2500	62.0	62.6	63.7	67.3	67.8	68.1	68.5	68.8
3150	59.5	60.1	61.1	64.6	65.1	65.3	65.7	66.0
4000	58.2	58.8	59.8	63.2	63.6	63.9	64.3	64.6
5000	53.1	53.6	54.6	57.7	58.1	58.3	58.7	58.9
6300	50.2	50.7	51.6	54.5	54.9	55.2	55.5	55.7
8000	45.2	45.6	46.4	49.0	49.3	49.6	49.9	50.1
10000	44.6	45.0	45.8	48.4	48.7	49.0	49.3	49.5
12500	39.4	39.8	40.5	42.8	43.1	43.2	43.5	43.7
16000	34.8	35.2	35.8	37.8	38.0	38.2	38.5	38.6
20000	34.5	34.8	35.4	37.4	37.6	37.8	38.1	38.2
Overall dB(A)	73.1	73.7	74.8	78.4	78.8	79.2	79.6	79.9

Hz/Model	RC2-340	RC2-370	RC2-410	RC2-470	RC2-510	RC2-550	RC2-580	RC2-620
50	61.4	62.4	63.8	64.8	65.7	66.7	66.9	67.2
63	58.0	58.9	60.2	61.1	62.0	62.9	63.1	63.4
80	63.5	64.5	66.0	67.0	67.9	68.9	69.2	69.4
100	60.3	61.2	62.6	63.6	64.4	65.4	65.7	65.9
125	59.8	60.8	62.2	63.1	64.0	64.9	65.2	65.4
160	59.3	60.2	61.6	62.5	63.3	64.3	64.5	64.8
200	57.0	57.9	59.2	60.1	60.9	61.8	62.0	62.3
250	67.5	68.5	70.1	71.2	72.1	73.2	73.5	73.8
315	62.6	63.6	65.1	66.1	67.0	67.9	68.2	68.5
400	59.4	60.4	61.8	62.7	63.5	64.5	64.7	65.0
500	64.4	65.4	66.9	67.9	68.8	69.8	70.1	70.4
630	62.0	63.0	64.4	65.4	66.3	67.3	67.5	67.8
800	72.4	73.5	75.2	76.3	77.3	78.5	78.8	79.1
1000	66.8	67.9	69.4	70.5	71.4	72.5	72.7	73.0
1250	74.7	75.9	77.6	78.8	79.9	81.0	81.3	81.7
1600	70.5	71.6	73.3	74.4	75.4	76.5	76.8	77.1
2000	69.3	70.4	72.0	73.1	74.1	75.1	75.4	75.7
2500	69.3	70.4	72.0	73.1	74.1	75.1	75.4	75.7
3150	66.4	67.5	69.0	70.1	71.0	72.1	72.4	72.6
4000	65.0	66.0	67.5	68.6	69.5	70.5	70.8	71.1
5000	59.4	60.3	61.7	62.6	63.4	64.4	64.6	64.9
6300	56.1	57.0	58.3	59.2	60.0	60.9	61.1	61.3
8000	50.4	51.2	52.4	53.2	53.9	54.7	54.9	55.1
10000	49.8	50.6	51.7	52.5	53.2	54.0	54.2	54.5
12500	44.0	44.7	45.7	46.4	47.0	47.7	47.9	48.1
16000	38.9	39.5	40.4	41.0	41.6	42.2	42.3	42.5
20000	38.5	39.1	40.0	40.6	41.1	41.7	41.9	42.1
Overall dB(A)	80.4	81.5	83.1	84.2	85.2	86.3	86.6	86.9

Hz/Model	RC2-710	RC2-790	RC2-830	RC2-930	RC2-1020	RC2-1130	RC2-1270	RC2-1530
50	67.4	67.5	67.8	68.5	70.0	70.3	70.6	70.9
63	63.5	63.7	63.9	64.6	66.0	66.3	66.6	66.9
80	69.6	69.8	70.1	70.8	72.3	72.7	73.0	73.3
100	66.1	66.3	66.5	67.2	68.7	69.0	69.3	69.6
125	65.6	65.8	66.0	66.7	68.1	68.5	68.7	69.1
160	65.0	65.1	65.4	66.0	67.5	67.8	68.1	68.4
200	62.4	62.6	62.8	63.5	64.9	65.2	65.4	65.8
250	74.0	74.1	74.4	75.2	76.8	77.2	77.5	77.9
315	68.7	68.8	69.1	69.8	71.3	71.7	72.0	72.3
400	65.2	65.3	65.6	66.2	67.7	68.0	68.3	68.6
500	70.6	70.7	71.0	71.7	73.3	73.7	73.9	74.3
630	68.0	68.1	68.4	69.1	70.6	70.9	71.2	71.6
800	79.3	79.5	79.8	80.6	82.4	82.8	83.1	83.5
1000	73.2	73.4	73.7	74.4	76.1	76.5	76.7	77.1
1250	81.9	82.1	82.4	83.2	85.1	85.5	85.8	86.2
1600	77.3	77.5	77.8	78.6	80.3	80.7	81.0	81.4
2000	75.9	76.1	76.4	77.2	78.9	79.3	79.6	80.0
2500	75.9	76.1	76.4	77.2	78.9	79.3	79.6	80.0
3150	72.8	73.0	73.3	74.0	75.7	76.1	76.3	76.7
4000	71.3	71.4	71.7	72.4	74.0	74.4	74.7	75.0
5000	65.1	65.2	65.5	66.1	67.6	67.9	68.2	68.5
6300	61.5	61.7	61.9	62.5	63.9	64.2	64.4	64.8
8000	55.3	55.4	55.6	56.2	57.4	57.7	57.9	58.2
10000	54.6	54.7	55.0	55.5	56.7	57.0	57.2	57.5
12500	48.2	48.3	48.5	49.0	50.1	50.3	50.5	50.8
16000	42.6	42.7	42.9	43.3	44.3	44.5	44.7	44.9
20000	42.2	42.3	42.5	42.9	43.8	44.1	44.2	44.4
Overall dB(A)	87.1	87.3	87.6	88.4	90.1	90.5	90.8	91.2

Note:

1. The above 1/3 octave spectrum datum is based on C/T 50°C, E/T 0°C, with R22.
2. For all compatible refrigerants of R22, R134a, R407C and the working conditions acceptable in limitation of Hanbell screw compressors, it has very similar value at all respective bars as above Sound Pressure Level chart with ±2dBA tolerance of OVERALL value at any working condition by any refrigerant.
3. The above datum is based on ISO-2151 to be measured.